

TOSHIBA

SERVICE MANUAL

VIDEO WALL PROJECTION UNIT

P600DL

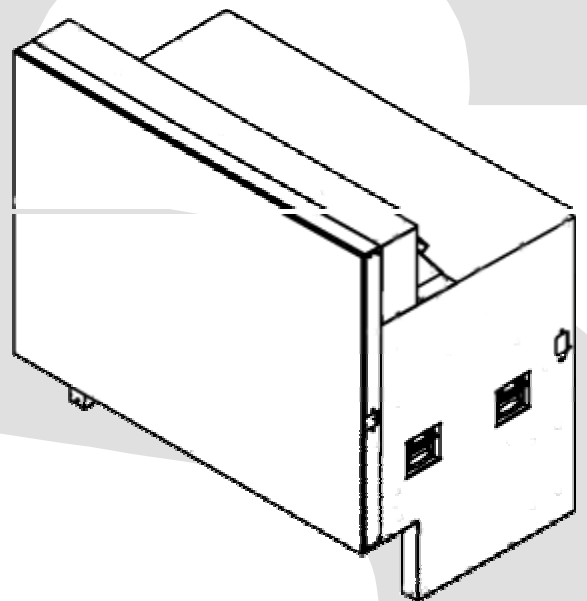



A TEXAS INSTRUMENTS TECHNOLOGY

SAFETY PRECAUTION

WARNING: Service should not be attempted by anyone unfamiliar with the necessary precautions on this projector. The following are the necessary precautions to be observed before servicing this chassis.

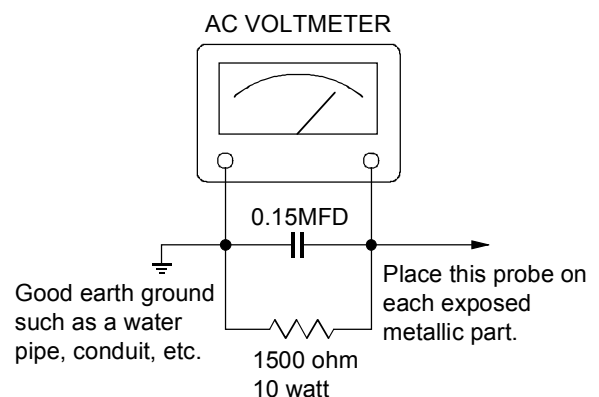
1. An isolation Transformer should be connected in the power line between the projector and the AC line before any service is performed on the projector.
2. When replacing a chassis in the cabinet, always be certain that all the protective devices are put back in place, such as; non-metallic control knobs, insulating covers, shields, isolation resistor-capacitor network etc.
3. Before returning the set to the customer, always perform an AC leakage current check on the exposed metallic parts of the cabinet, such as terminals, screwheads, metal overlays, control shafts etc. to be sure the set is safe to operate without danger of electrical shock. Plug the AC line cord directly into a AC outlet (do not use a line isolation transformer during this check). Use an AC voltmeter having 5000-ohm per volt or more sensitivity in the following manner: Connect a 1500-ohm 10W resistor, paralleled by a 0.15-MFD, AC type capacitor, between a known good earth ground (water pipe, conduit, etc.) and the exposed metallic parts, one at a time. Measure the AC voltage across the combination of 1500-ohm resistor and 0.15-MFD capacitor. Reverse the AC plug at the AC outlet and repeat AC voltage measurements for each exposed metallic part. Voltage measured must not exceed 5.25V(rms). This corresponds to 3.5mA(AC). Any value exceeding this limit constitutes a potential shock hazard and must be corrected immediately.



PRODUCT SAFETY NOTICE

Many electrical and mechanical parts in this chassis have special safety-related characteristics. These characteristics are often passed unnoticed by a visual inspection and the protection afforded by them cannot necessarily be obtained by using replacement components rated for higher voltage, wattage, etc. Replacement parts which have these special safety characteristics are identified in this manual and its supplements; electrical components having such features are identified by the international hazard symbols on the schematic diagram and the parts list.

Before replacing any of these components, read the parts list in this manual carefully. The use of substitute replacement parts which do not have the same safety characteristics as specified in the parts list may create shock, fire or other hazards.

ULTRAVIOLET DANGER IN SERVICE MODE

Eye damage may result from directly viewing the light produced by the lamp used in this product. Always turn off lamp before opening this cover. Ultraviolet radiation eye protection required during servicing.

CONTENTS

SAFETY PRECAUTIONS FOR USER	3
PRECAUTIONS FOR USE AND MAINTENANCE	7
GENERAL DESCRIPTIONS	8
1. FEATURES	8
2. DIMENSIONS	9
3. PART NAMES AND FUNCTIONS	10
3-1. I/O PANEL	10
3-2. POWER PANEL	11
4. POWER SWITCH AND POWER INDICATOR	11
5. SPECIFICATIONS	12
6. ACCEPTABLE SIGNAL TYPE	13
7. ACCEPTABLE RGB INPUT SIGNAL TIMING	14
8. CONNECTION AT A MULTI-PROJECTION SYSTEM	15
DISASSEMBLY	16
1. HOW TO REPLACE THE LAMP	16
2. LOCATION OF KEY COMPONENTS AND FUNCTION MODULE	18
3. EXPLODED VIEW OF THE PROJECTION BLOCK	19
5-1. Removing the DLP engine	20
5-2. Installing the DLP engine	20
4. EXPLODED VIEW OF THE SCREEN BLOCK AND CABINET	21
5. WIRING	22
ADJUSTMENT	23
1. ADJUSTING THE DLP ENGINE	23
2. ADJUSTING THE ENGINE MOUNT	24
3. ELECTRONICS ADJUSTMENT OR SETTING	26
3-1. Input Signal selection	26
3-2. Adjust Mode	27
3-3. Saving adjustments	27
3-4. Adjustment parameters	27
3-5. Internal Test Pattern	27
3-6. White Balance adjustment	27
3-7. Gain and Off-Set	27
3-8. Clock frequency adjustment and phase adjustment	28
3-9. Image position adjustment	28
3-10. Screen Mode Selection	28
3-11. On-Screen-Display, OSD	28
3-12. Video Enhancer	28
3-13. Interpolation Filter	28
3-14. Image direction	28
3-15. Status Indication	28
3-16. Power ON delay	28
4. Multiple Screen Wall system (example)	29
5. ID Assignment (example)	29
5-1. Clearing I.D.	29
5-2. Setting I.D.	29
5-3. Selecting I.D.	29
6. Magnification	29

Electric Circuit Explanation	30
1. RGB/Control PCB	30
2. DMD Driver PCB	31
3. Power Supply PCB	31
4. Lamp Ballast PCB	31
5. RS232C Control PCB	31
6. Video PCB	31

APPENDIX

1. P600DL control board LED status	32
2. Control via RS-232C -Command Protocol List	33
3. DMD Driver board debug	37
4. PARTS LIST	42



SERVICING DIAGRAM

1. DMD Driver Board Block Diagram	44
2. Signal Process Section Block Diagram	45
3. Wiring Diagram	46
4. ENTIRE BLOCK DIAGRAM	47
5. DMD Board Micro controller	48
6. DMD Display Controller	49
7. DMD Data Formatter	50
8. DMD Memory	51
9. DMD Switching Voltage	52
10. DMD Positive Bias	53
11. DMD Reset ASIC Driver	54
12. DMD Imager	55
13. Motor Rotation Sensor	56
14. Video Input Buffer	57
15. RS-232C Board	58
16. PFC & Main Power Supply	59
17. Sub Power Supply	60
18. Video Decoder	61
19. Voltage Regulator and Fan Control	62
20. 96-pin Connector & D/A Converter	63
21. Magnification Scaler	64
22. MAG/Freq Conv Control MPU	65
23. Freq Conv Scaler	66
24. Freq Conv Scaler	67
25. Analog SW & A/D Converter	68
26. DVI Input Buffer	69
27. DVI Output Buffer	70

SAFETY PRECAUTIONS FOR USER

On the product and in the operation manual, precautions are presented to protect you and other persons from injuries and properties from damage and to use this equipment safely.

Indications and symbols for such precautions are as shown below.

 WARNING	Wrong operation or incorrect handling with ignoring this indication may result in death or serious injury of users and third parties.
 CAUTION	Wrong operation or incorrect handling with ignoring this indication may result in serious injury of users and third parties and damage of properties.

First things to be observed

When installing or move the equipment:

WARNING

Installation or transportation of this equipment shall be entrusted to vendors qualified by " Toshiba Lightning and Equipment Technology ".

Installation and transportation by parties other than qualified vendors may result in injury or damage of the equipment. Also, improper power connection may result in fire disasters.

For installation works, Please refer to the contents of the "Items to be checked before installation works by qualified vendor".

Items to be observed upon use of this equipment

For abnormality or trouble

WARNING

When smoke or strange smell comes out of the equipment, cut off the power circuit breaker immediately and disconnect the power plug from the outlet.

After confirming smoke stopped coming out, contact your dealer for repair.

If you should continue using the equipment, fire or electric shocks may result.

When no image appears on the screen, cut off the power circuit breaker immediately and disconnect the power plug from the outlet.

If you should continue using the equipment, fire or electric shocks may result. Contact your dealer for repair.

When water or a foreign matter should get in the equipment, cut off the power circuit breaker immediately and disconnect the power plug from the outlet.

If you should continue using the equipment, fire or electric shocks may result. Contact your dealer for repair.

When the equipment should fall down or the cabinet is broken, cut off the power circuit breaker immediately and disconnect the power plug from the outlet.

If you should continue using the equipment, fire or electric shocks may result. Contact your dealer for repair.

For use of the equipment

WARNING

Do not remove the rear cover, cabinet or the cover.

There are high-voltage parts in the unit. Touching components inside may result in electric shocks.

Do not repair or reconstruct the equipment by the user.

Never attempt to do so, otherwise fire disaster or electric shocks may result. For repair, contact your dealer.

Do not damage, break, modify, bend forcibly, tug, twist, bundle, put a heavy thing on or heat the power cable.

If the equipment is used with damaged power cable, fire disaster or electric shocks may result.

If the cable is damaged, contact your dealer for repair.

Do not insert or drop metals or combustible into the equipment though the vent holes, etc.

Fire disaster or electric shocks may result.

Do not put thing on the equipment.

When metals or liquid should get in the equipment, fire or electric shocks may result. Also, a heavy thing may drop from the unit, resulting in injury.

Do not humidify the atmosphere around the unit. Do not place a humidifier near the unit.

High humidity may cause fire or electric shocks. Also, the screen may be degraded and broken, resulting in injury.

CAUTION

When disconnecting the power plug, do not pull the power cable.

Make sure to hold the plug to disconnect. If you pull the cable, the cable may be damaged, causing fire or electric shocks.

Do not connect/disconnect the power plug with wet hands.

It may cause electric shocks.

Do not step on the equipment, or put a heavy thing on it.

The equipment will lose the balance and fall down or be broken, causing injury. Also, the equipment may be deformed, causing fire or electric shocks.

When leaving the equipment out of use for a long time, make sure to disconnect the power plug from the outlet for safety.

When the power supply is cut off by the controller, the equipment is placed in the stand-by mode and electricity is still consumed for the functions to turn on the power by the controller. Also, if a trouble should occur, it may cause fire disaster.

Do not block the vent ports of the equipment, or obstruct air flow around the equipment.

When the vent ports are blocked, temperature inside will rise and cause fire disaster. For example, avoid using the equipment in the following manners.

(1) Cover the equipment with a cloth or curtain.

(2) Place packages around the equipment or stand things against the equipment.

Do not expose the equipment to oily smoke or steam, or do not use the equipment in dusty atmosphere. It may cause fire or electric shocks.

Do not expose the equipment to wind and rain.

The screen may drop or fall down due to wind and cause injury. Or rain may result in fire or electric shocks.

For servicing, maintenance and inspection

WARNING

If dust and dirt attached on the blades or the blade clamping face of the power plug, clean the dust and dirt from the plug.

Otherwise, fire may occur due to lowering of insulation of the power plug.

CAUTION

Make a maintenance contract with the dealer and entrust the dealer with periodical inspection and adjustment.

If the equipment is left for long time without cleaning dust inside the equipment, fire, electric shocks, trouble of the equipment may result.

Servicing of the equipment shall be done after disconnecting the power plug from the outlet.

Otherwise electric shocks may result.

Pay attention for the connection cables.

Injury may occur by being caught by or stumbling on the cables. In addition, the equipment may fall down, resulting in injury.

Items to be confirmed with the qualified vendor for installation works

WARNING

Do not use the equipment outdoors, fire or electric shocks may result.

This equipment has been designed exclusively for indoor use.

Do not install the equipment on unstable places.

The equipment may drop or fall down, resulting in injury.

Install the equipment on a rigid and level floor.

Confirm that the installation works are done for sufficient withstanding force against the overall load of piled-up units and vibration of earthquake, etc. If the installation is unstable, the equipment may drop or fall down, resulting in injury.

Do not install the equipment at places exposed to direct sunshine, or where temperature rises, such as a place near heater, etc.

If the temperature inside the equipment rises, fire may result.

Do not use the equipment in places with high humidity, such as a bathroom or a place near a humidifier.

It may cause fire or electric shocks. Also, the screen may be broken, resulting in injury.

Do not use the equipment with power voltages other than the one indicated on the equipment.

Otherwise, fire or electric shocks may result.

Make sure to install a circuit breaker in the power supply line exclusively for the equipment.

Otherwise, fire may occur because power supply cannot be cut off immediately when trouble or abnormality occurs in the equipment.

The socket-outlet shall be installed near the equipment and shall be easily accessible.

Make sure to provide ground line from the ground terminal of the power plug.

Otherwise, electric shocks may result.

Do not connect many loads on a single outlet.

It may cause fire or electric shocks due to overload.

Do not put things on the equipment.

When metals or liquid should get in the equipment, fire or electric shocks may result. Also, a heavy thing may drop from the unit, resulting in injury.

Secure the equipment to the building.

A high projection system may topple during an earthquake. Human life and property may sustain great damage if a system topples. Prevent toppling and accidents. Following offers some examples of how to avoid toppling. Use the most appropriate one

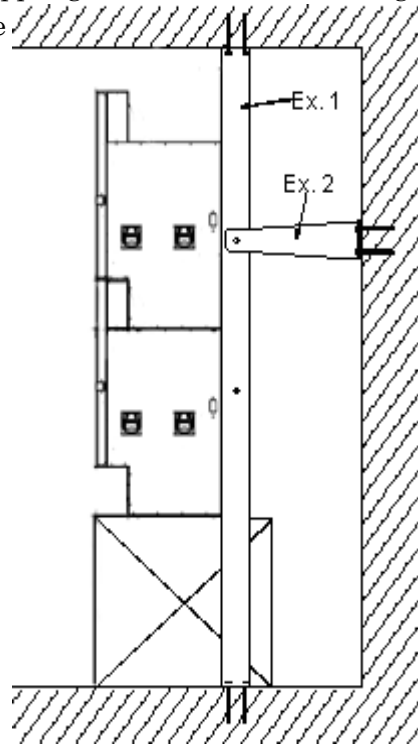

⚠ CAUTION

Do not block the vent ports of the equipment, or obstruct air flow around the equipment.

When the vent ports are blocked, temperature inside will rise and cause fire disaster. For example, avoid using the equipment in the following manners.

- (1) Install the equipment in places with poor ventilation.
- (2) Place the equipment facing up, sideways, or upside-down.
- (3) Place the equipment on a carpet or bedding.
- (4) Cover the equipment with a cloth or curtain.
- (5) Place packages around the equipment or stand things against the equipment.
- (6) Press the equipment against walls.(At the rear side of the equipment, a space for maintenance and inspection is needed.)

Do not place the equipment at places where it may be exposed to oily smoke or steam such as a place near a cooking area, etc. or at dusty places.

Do not place the equipment at places where it may be exposed to wind and rain.

The screen may drop or fall down due to wind and cause injury. Or rain may result in fire or electric shocks.

PRECAUTIONS FOR USE AND MAINTENANCE

Request to User

Screen protector

Screen protectors are provided to protect the screen from scratching and separation during transportation.

Please remove screen protectors before using the projection unit and attach them when storing or transporting the projection unit.

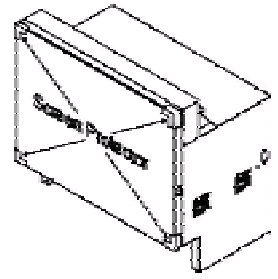

Precautions on Use

Connection of a grounded cable

Ground the projection unit in order to prevent electric shock with 3-core power cable. There is greater danger of electric shock when multi projection units are used without ground wire connected.

Condensation

When room temperature rises rapidly (or the video wall projection unit is moved from a cold place to a hot place), condensation may form on the lens, causing picture distortion or color fade-out. In such cases, wait for a while (with keeping power ON) until the condensation clears.

About radiator fan

The radiator fan in the projection unit needs to be replaced after about three years of use. Contact your dealer for the replacement work.

Maintenance

Do not use solvent or paint thinner

If these are used, coating layer may peel off or deteriorate. If rubber or plastic comes into contact with the projection unit for a long time, the projection unit may be stained.

Care of the screen

After switching the power supply off, gently wipe the screen with a soft cloth. Since the screen surface is easily scratched, do not rub it with a hard object. Never use a chemical duster.

Care of the cabinet

After switching the power supply off, wipe gently with soft cloth.

When using a chemical duster, follow the maker's precautions.

GENERAL DESCRIPTIONS

FEATURES

- Digital Light Processing™ (DLP™) by Texas Instruments
P600DL is a projection unit using the Texas Instruments' Digital Mirror Device (DMD)™ optical element. The DLP™, Digital Light Processing™ engine is constructed with the DMD chip, with XGA resolution.

- Flexible input capability
From Video signal (NTSC/PAL) to SXGA 75Hz are compatible.
Incoming PC signal timing should be followed the VESA standard.
XGA signal is reproduced on screen without having any scaling function.
The other frequencies are converted to XGA resolution inside the cube. See note 1.

- Internal magnification
A multi-screen system can be formed easily with an internal magnification function from 1x1 to 6x6 with some popular magnification ratio as 2x3, 3x4 or 4x5.

- Digital signal link between units
The unit has digital I/O interface. A signal supplied to 1st unit, master cube, is distributed to the following cube with DVI digital Link Cable. Signal distributor and other signal cables are not necessary. See Note 2 below.

- Superior image quality
 - * Native resolution of XGA, 1024x768 pixels
 - * No burn-in unlike projection tube
 - * High Contrast image by 12-degree mirror flip DMD chip

- Easy installation and maintenance
 - * Convergence free between colors
 - * Steady geometric alignment
 - * Engine installed at factory
 - * Easy replacement 6000H (Survival rate of 50%) UHP 120W lamp, See Note 3

- Low power consumption
120W UHP lamp is used for light source.
Total power consumption is 200W.

- Highly reliable control system
Projection system can be controlled with a PC via RS232C cable. Also most of the control/adjustment is possible to do with optional wired remote control, CT-90000.
RS232C IN/OUT are to send command and also for communication between cubes.

- Mechanical function
Screen escutcheon can be removed from front.
Almost all the connection cables can be hidden inside the cube.

Note 1: This does not mean that all the signals are accepted. For acceptable signals, refer to the later page in Acceptable Signal Type and also Acceptable RGB input Signal Timing.

Note 2: Maximum number of units which can be connected via Digital Signal Link is depend on input signal quality, including S/N and jitter, etc..

Note 3: The lamp is expected to last more than 4000H, with the recent information, it will be more than 6000H, with survival rate of 50%, however, the actual life of each lamp varies depending on conditions of use. For warranty and exchange of lamp, please check with your dealer/distributor.

DIMENSIONS

FRONT

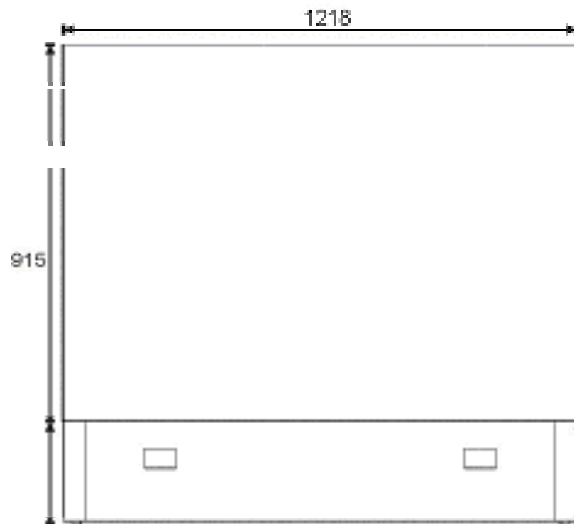

REAR

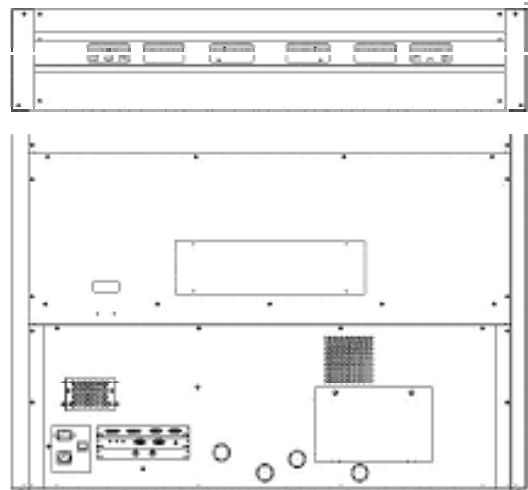

SIDE

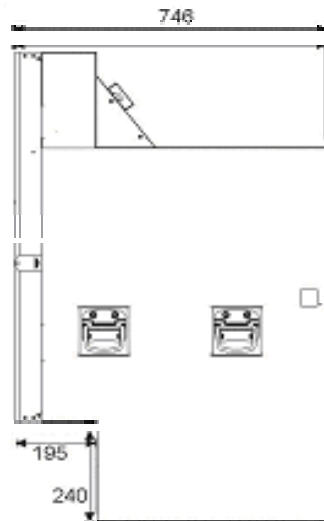

TOP

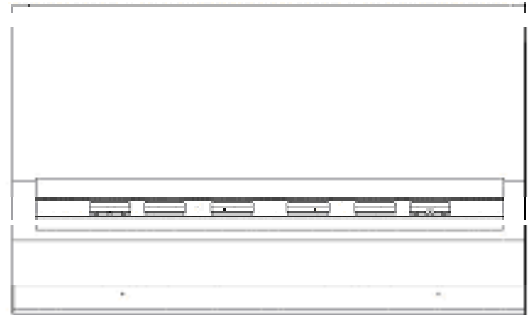

FUNCTION OF I/O PANEL

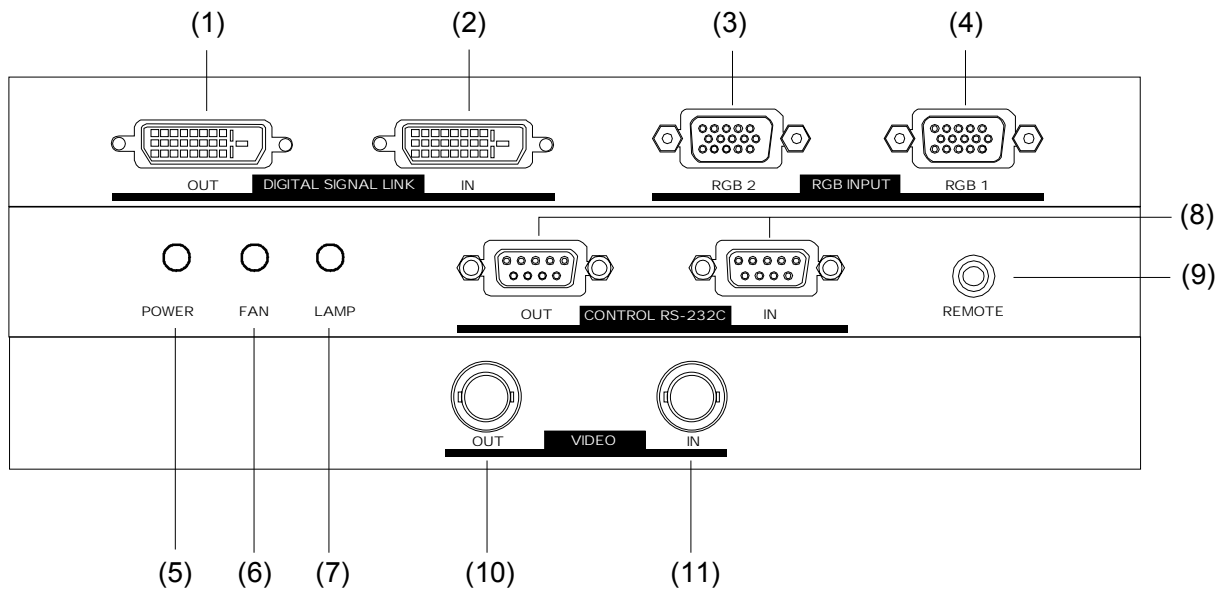

No.	Name	Function	Remarks
1	Digital Signal Link terminal	Cube signal transfer	OUT: 24-pin DVI-D
2	Digital Signal Link terminal	Cube signal transfer	IN: 24-pin DVI-D
3	RGB-2 input	RGB Signal Input - 2	D-sub HD15-pin (female)
4	RGB-1 input	RGB Signal Input - 1	D-sub HD15-pin (female)
5	Power indicator	Power status indication	Green/Red LED
6	Fan indicator	Fan Status indication	Green LED
7	Lamp indicator	Lamp Status indication	Green LED
8	RS-232C port	RS-232C communication [SELV circuit: max. + - 12V]	OUT: 9-pin D-sub (male) IN: 9-pin D-sub (female)
9	Remote control	Wired remote control	3.5mm Stereo Mini Jack
10	Video Output	Composite Video loop output	BNC
11	Video Input	Composite Video Input	BNC

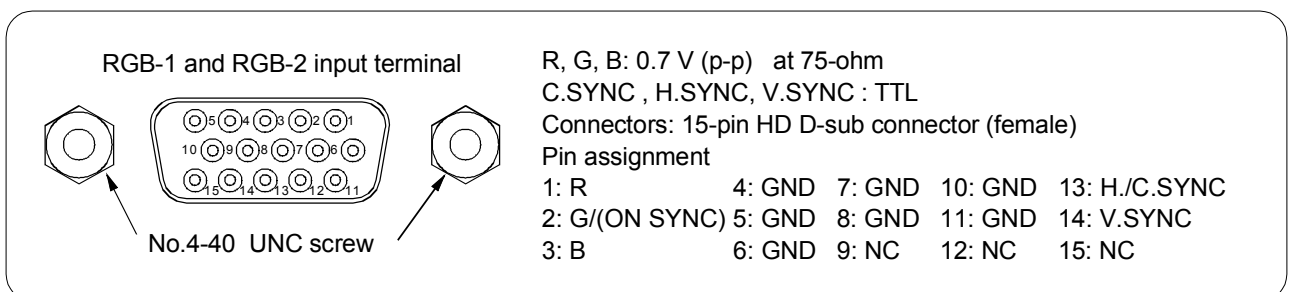

FUNCTION OF POWER PANEL

REAR OF CABINET

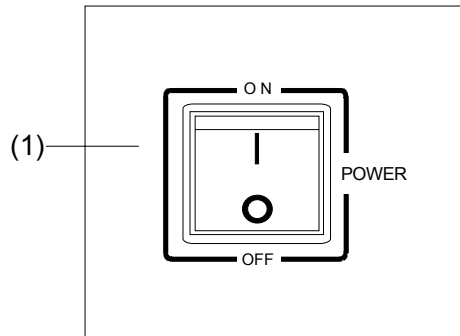

INSIDE OF CABINET

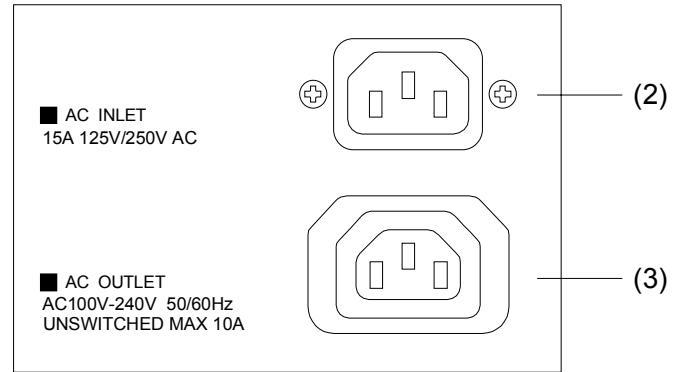

No.	Name	Function	Remark
1	Power Switch	Turn ON and OFF main power	ON/OFF
2	AC Inlet	AC 100-240V, 50/60Hz input	3P plug
3	AC Outlet	AC outlet, un-switched, max 10A	3P socket

Note 1: The AC outlet supplies un-switched power source to a second unit in a multi-projection system. Do not use it for any other purpose. Serial connection using this power outlet must be maximum four units including the 1st unit.

Note 2: The plug type of the projection unit power cable may not match the AC outlet. When power is to be supplied to another unit from this AC outlet, please purchase necessary power cable.

Note 3: About Power Supply cord

The Power Supply cord must be in accordance with the applicable standards.

A three-core cord, one for ground, must be used.

The power cord must be at least 1.0mm² and H05VV-F.

POWER SWITCH AND POWER INDICATOR

AC power source is turned-on/off with the Power Switch. When the Power Switch is turned-on, the Power Indicator lights in green color and a projection unit enters active state.

It takes about 30 seconds typically till an image is shown after Power Switch is turned-on.

In the active state, it is possible to power on/off with an external controller. When power is turned-off with an external controller, the Power Indicator lights in red color and a projection unit enters standby state.

Interval from turn-off to turn-on shall be more than 30 seconds. If the interval is not enough, the lamp may not strike. If the user continues to do this, it may shorten the life of the lamp.

The power indicator indicates also failure information of the projection unit.

The later page at appendix list shows the lamp status.

SPECIFICATIONS

Model name	P600DL
Type	60-inch rear projection unit
Acceptable signals	Refer to page 13 and page 14.
Image device	1 chip XGA Digital Mirror Device ^(R)
Light source	120W UHP lamp
Resolution	1024 x 768 dot (Include part hidden with screen frame)
Brightness	300cd/m ² (Typ.)
Screen	Fresnel sheet (internal), Lenticular sheet (external)
Screen frame	0.7mm average
Viewing Angle	Horizontal: Min. 150 degrees, Vertical: Min. 60 degrees
Color temperature	Selection of three user defines
Operating temperature	5-35 °C (41-95 °F)
Operating humidity	30-70 % (Relative humidity non-condensing)
Power requirement	AC100-240V, 50/60Hz, 200W (200VA)
Dimensions	1200.6 (W) x 1161.9 (H) x 754.7 (D) mm (48 x 45.7 x 29.3 inches) protrusions not included
Weight	70kg
Accessories	Owner's Manual, DVI link cable, RS232C link cable, Assembly parts

Video Input	Terminal	Not available (Optional Video Input Card : BNC IN/OUT)
	Level	(Optional Video Input Card : 1.0Vp-p composite video, PAL/NTSC)
RGB Input	Terminal	RGB-1 input / RGB-2 input: HD D-sub 15pin (female) connector x 2
	Level	R/G/B signal: 0.7Vp-p (75-ohm termination) H.SYNC / V.SYNC / C.SYNC signals: TTL
External control		System: RS-232C, Terminal: D-sub 9pin (female) connector x 1 Speed: 1200, 2400, 4800, 9600 baud
Communication Link		System: RS-232C, Terminal: D-sub 9pin connector x 2 for IN and OUT
Digital Signal Link		System: TMDS, Terminal: DVI-D 24pin connector x 2 for IN and OUT
Remote Control Terminal		3.5mm terminal for optional Remote Controller

The Digital Signal Link is used for signal transmission between projection units and this does not support external input signal.

The specifications and design of this product are subject to change without notice.

ACCEPTABLE SIGNAL TYPE

The following are acceptable input signal types.

Projection unit automatically distinguishes mode according to frequency of input signal. All the signals accepted are displayed on screen with 1024x768 dot by internal resolution converter.

The Digital Signal Link function may not support NTSC/PAL/SECAM signal supplied from RGB-1 and RGB-2 input terminal. Also, Digital Signal Link function may not support unstable signal either.

Format Type	Mode	H. Freq.	V. Freq.	Input Resolution	Sync Pol. H/V	Scan Type	Input Terminal
NTSC @R,G,B,H,V	NTSC	15.734	59.94		N/N	Interlaced	RGB IN
PAL/SECAM @R,G,B,H,V	PAL	15.625	50.00		N/N	Interlaced	RGB IN
HDTV @R,G,B,H,V	HDTV	33.75	60.00		N/N	Interlaced	RGB IN
NEC PC98 Standard @56Hz	NEC24k	24.82	55.90	640 x 400	N/N	Noninterlaced	RGB IN
VGA Graphic 350 Lines @70Hz	TEXT70	31.47	70.09	640 x 350	P/N	Noninterlaced	RGB IN
VGA Graphic 400 Lines @70Hz	TEXT70	31.47	70.09	640 x 400	N/P	Noninterlaced	RGB IN
VGA Text 350 Lines @70Hz	TEXT70	31.47	70.09	720 x 350	P/N	Noninterlaced	RGB IN
VGA Text 400 Lines @70Hz	TEXT70	31.47	70.09	720 x 400	N/P	Noninterlaced	RGB IN
VESA 640 x 350 @85Hz	TEXT85	37.861	85.08	640 x 350	P/N	Noninterlaced	RGB IN
VESA 640 x 400 @85Hz	TEXT85	37.861	85.080	640 x 400	N/P	Noninterlaced	RGB IN
VESA 720 x 400 @85Hz	TEXT85	37.927	85.039	720 x 400	N/N	Noninterlaced	RGB IN
VESA 640 x 480 @60Hz	VGA60	31.469	59.940	640 x 480	N/N	Noninterlaced	RGB IN
VESA 640 x 480 @72Hz	VGA72	37.861	72.809	640 x 480	N/N	Noninterlaced	RGB IN
VESA 640 x 480 @75Hz	VGA75	37.50	75.000	640 x 480	N/N	Noninterlaced	RGB IN
VESA 640 x 480 @85Hz	VGA85	43.269	85.008	640 x 480	N/N	Noninterlaced	RGB IN
Macintosh 13 Inch Mode @67Hz	MAC13	35.000	66.667	640 x 480	- / -	Noninterlaced	RGB IN
VESA 800 x 600 @56Hz	SVGA56	35.156	56.250	800 x 600	P/P	Noninterlaced	RGB IN
VESA 800 x 600 @60Hz	SVGA60	37.879	60.317	800 x 600	P/P	Noninterlaced	RGB IN
VESA 800 x 600 @72Hz	SVGA72	48.077	72.188	800 x 600	P/P	Noninterlaced	RGB IN
VESA 800 x 600 @75Hz	SVGA75	46.875	75.000	800 x 600	P/P	Noninterlaced	RGB IN
VESA 800 x 600 @85Hz	SVGA85	53.674	85.061	800 x 600	P/P	Noninterlaced	RGB IN
Macintosh 16 Inch Mode @75Hz	MAC16	49.725	74.550	832 x 624	- / -	Noninterlaced	RGB IN
VESA 1024 x 768 @43Hz	XGA43	35.522	43.479	1024 x 768	P/P	Interlaced	RGB IN
VESA 1024 x 768 @60Hz	XGA60	48.363	60.004	1024 x 768	N/N	Noninterlaced	RGB IN
VESA 1024 x 768 @70Hz	XGA70	56.476	70.069	1024 x 768	N/N	Noninterlaced	RGB IN
VESA 1024 x 768 @75Hz	XGA75	60.023	75.029	1024 x 768	P/P	Noninterlaced	RGB IN
VESA 1024 x 768 @85Hz	XGA85	68.677	84.997	1024 x 768	N/N	Noninterlaced	RGB IN
Macintosh 19 Inch Mode @75Hz	MAC19	60.135	74.700	1024 x 768	N/N	Noninterlaced	RGB IN
WK Stn 1280X1024@60Hz	SXGA	64.00	60.000	1280 X 1024	N/N	Noninterlaced	RGB IN
1028 x 1024 @75Hz	SXGA	79.976	75.025	1280 X 1024	P/P	Noninterlaced	RGB IN

Note 1: In composite sync or sync-on-green signal, H sync signal must be inserted into V sync signal.

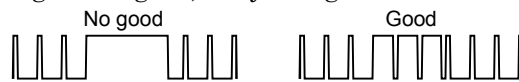

Note 2: In H/V separation sync signal, V sync signal must not be included H sync signal or equalization pulse. Also, H sync signal must not included V sync signal and equalization pulse.

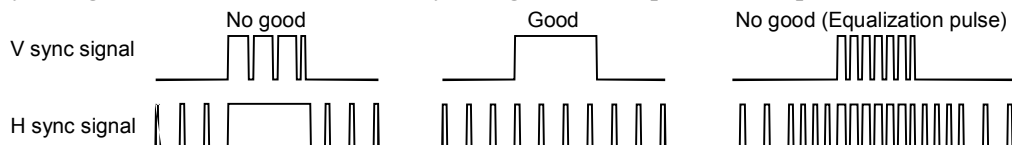

Note 3: When composite sync or sync-on-green signal is supplied, horizontal frequency must be 31 kHz or higher.

Note 4: Sync signal : Horizontal Positive or Negative. Minimum H. sync width : 1 μ S
Vertical Positive or Negative. Minimum V. sync width : 2H

ACCEPTABLE RGB INPUT SIGNAL TIMING

Following are acceptable RGB input signal timings which have been tested by Toshiba. These are timings checked on the RGB input terminals of projection unit. If signal supplied is not exactly the same as one of the followings but is similar to one, it may be accepted by adjustment of projection unit.

When picture caused horizontal jitter or display position difference, adjust the projection unit with optional controller. However, when signal cable used or other factors have problems, timing may cause trouble and picture will not be stable. When signal is not stable, each function of projection unit will not be guaranteed for good picture display.

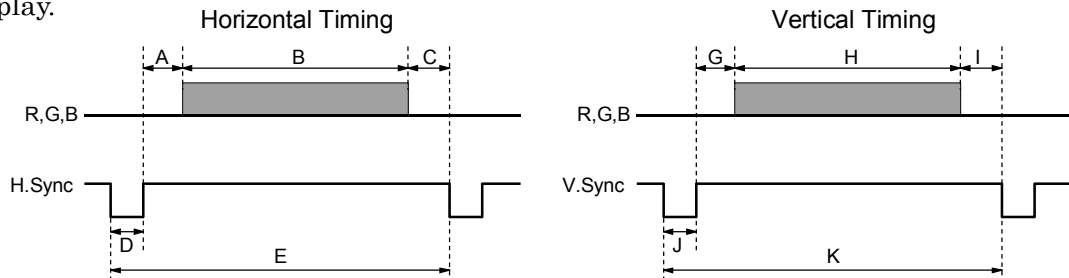

Mode	Input Resolution	A (Pixels)	B (Pixels)	C (Pixels)	D (Pixels)	E (Pixels)	fH (kHz)	fV (Hz)	Clock (MHz)	G (Lines)	H (Lines)	I (Lines)	J (Lines)	K (Lines)
NTSC							15.734	59.94	16.521					
PAL							15.625	50	16.406					
HDTV							33.75	60	67.264					
NEC24k	640 x 400	85	640	59	64	848	24.82	55.9	21.047	25	400	7	8	440
TEXT70	640 x 350	48	640	14	96	800	31.47	70.09	25.176	60	350	38	2	449
TEXT70	640 x 400	48	640	14	96	800	31.47	70.09	25.176	35	400	13	2	449
TEXT70	720 x 350	54	720	18	108	900	31.47	70.09	28.323	60	350	38	2	449
TEXT70	720 x 400	54	720	18	108	900	31.47	70.09	28.323	35	400	13	2	449
TEXT85	640 x 350	96	640	32	64	832	37.861	85.08	31.5	60	350	32	3	445
TEXT85	640 x 400	96	640	32	64	832	37.861	85.08	31.5	41	400	1	3	445
TEXT85	720 x 400	108	720	36	72	936	37.927	85.039	35.5	42	400	1	3	446
VGA60	640 x 480	40	640	24	96	800	31.469	59.94	25.175	25	480	18	2	525
VGA72	640 x 480	120	640	32	40	832	37.861	72.809	31.5	20	480	17	3	520
VGA75	640 x 480	120	640	16	64	840	37.5	75	31.5	16	480	1	3	500
VGA85	640 x 480	80	640	56	56	832	43.269	85.008	36	25	480	1	3	509
MAC13	640 x 480	96	640	64	64	864	35	66.667	30.24	39	480	3	3	525
SVGA56	800 x 600	128	800	24	72	1024	35.156	56.25	36	22	600	1	2	625
SVGA60	800 x 600	88	800	40	128	1056	37.879	60.317	40	23	600	1	4	628
SVGA72	800 x 600	64	800	56	120	1040	48.079	72.188	50	23	600	37	6	666
SVGA75	800 x 600	160	800	16	80	1056	46.875	75	49.5	21	600	1	3	625
SVGA85	800 x 600	152	800	32	64	1048	53.674	85.061	56.25	27	600	1	3	631
MAC16	832 x 624	224	832	32	64	1152	49.725	74.55	57.283	39	624	1	3	667
XGA43	1024 x 768	56	1024	8	176	1264	35.522	43.479	44.9	40	768	0	8	816
XGA60	1024 x 768	160	1024	24	136	1344	48.363	60.004	65	29	768	3	6	806
XGA70	1024 x 768	144	1024	24	136	1328	56.476	70.069	75	29	768	3	6	806
XGA75	1024 x 768	176	1024	16	96	1312	60.023	75.029	78.75	28	768	1	3	800
XGA85	1024 x 768	208	1024	48	96	1376	68.677	84.997	94.5	36	768	1	3	808
MAC19	1024 x 768	172	1024	34	96	1328	60.135	74.7	79.86	30	768	4	3	805
SXGA60	1280 x 1024	248	1280	48	112	1688	63.981	60.02	108	38	1024	1	3	1066
SXGA75	1280 x 1024	248	1280	16	144	1688	79.976	75.025	135	38	1024	1	3	1066

Note 1: The clock pulse is made in projection unit automatically. External clock input is not equipped.

Note 2: When 15kHz NTSC/PAL signal is supplied to the RGB input terminal, the Digital Signal Link function is not guaranteed for correct signal transfer.

Note 3: When signal except standard type (for example, played back software with a copy guard or a special effect play of VCR, etc.) is supplied to the RGB input terminal, projection unit may not function properly.

CONNECTION AT A MULTI PROJECTION SYSTEM

Following is example of connection for a multi-projection system using four projection units.

In this example, signal sources are supplied into the Unit-1 and a signal selected by the Unit-1 is supplied from Unit-1 to Unit-2 through Unit-4 with the Digital Signal Link.

The optional wired remote controller is connected to Unit-1 and all Units are controlled by the System Bus Link.

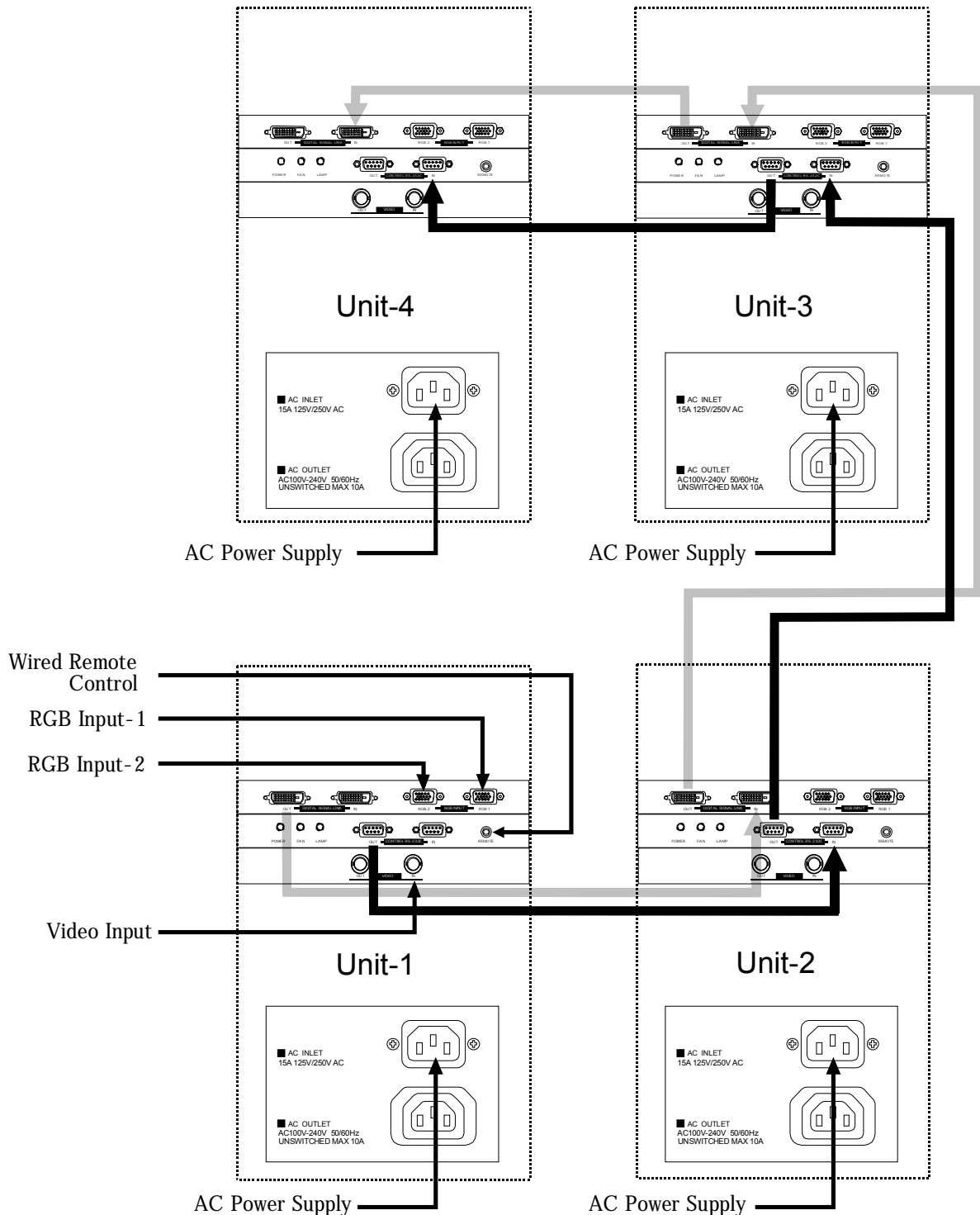

Note: Maximum number of units which can be connected via Digital Signal Link is dependent on input signal quality including S/N and jitter, etc.

DISASSEMBLY

1. HOW TO REPLACE THE LAMP

- 1) turn off the power switch and disconnect AC cord.
- 2) Open lamp door.
 - (1) Remove 2 screws.
 - (2) Open Lamp door. Be careful, lamp door switch is located at door.

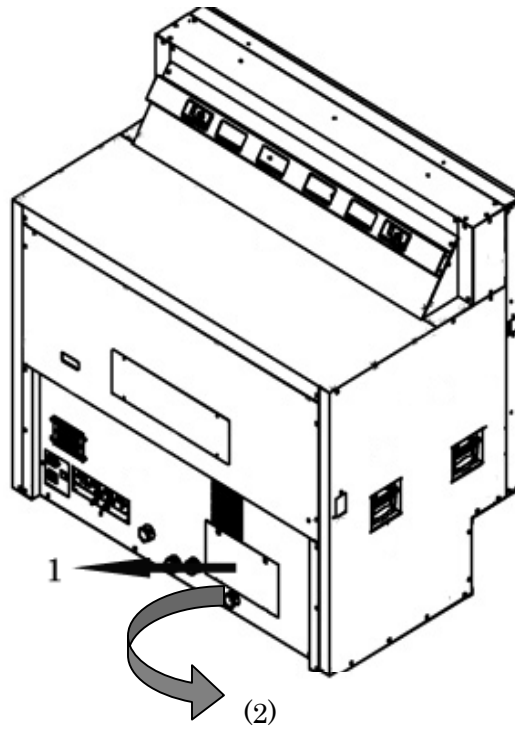

- 3) Remove Old lamp
 - (1) Rotate Lock lever down as picture shows.
 - (2) Pull the Lamp unit to the right and remove lamp.

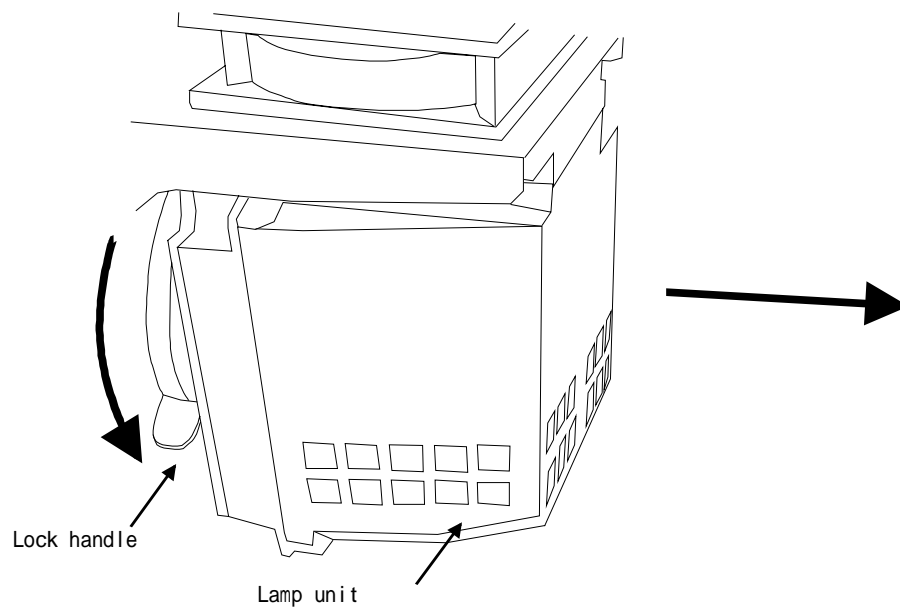

- 4) Attach new lamp
 - (1) Place the lamp housing to the guide rail and insert the lamp.
Check if the power supply connector is securely inserted.
 - (2) Lock the lamp housing rotating Lock lever.

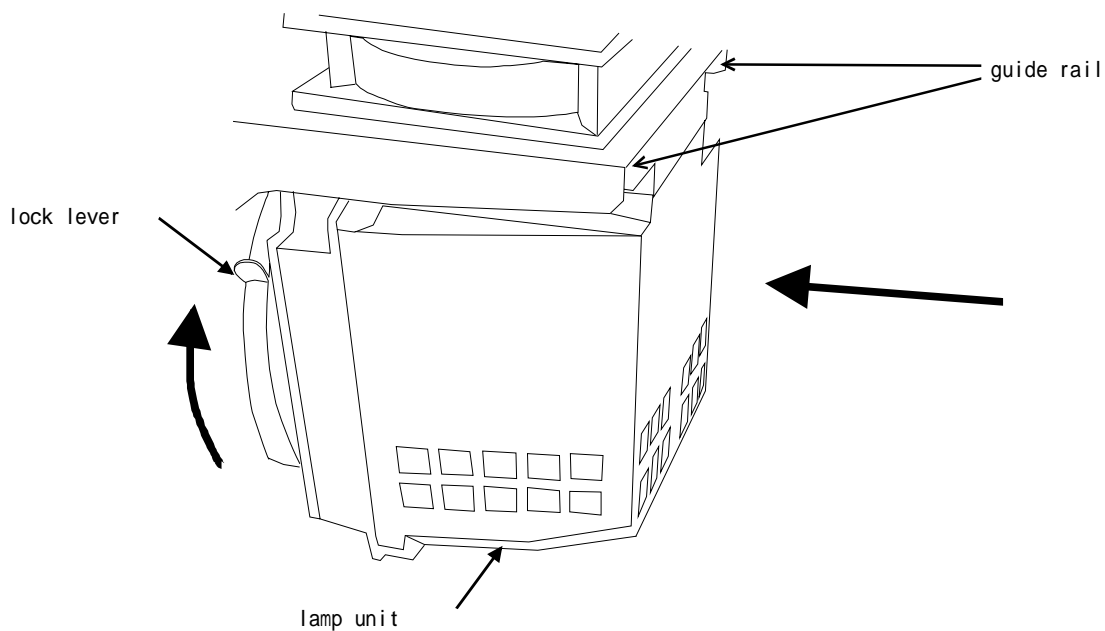

- 5) Attach lamp door.
- 6) Turn ON the power switch, connect PC with software, Cube commander, or remote control , then enter to the ADJUST mode → SPECIAL mode → F → STD thus the lamp timer is reset.

2 . LOCATION OF KEY COMPONENTS AND FUNCTION MODULE

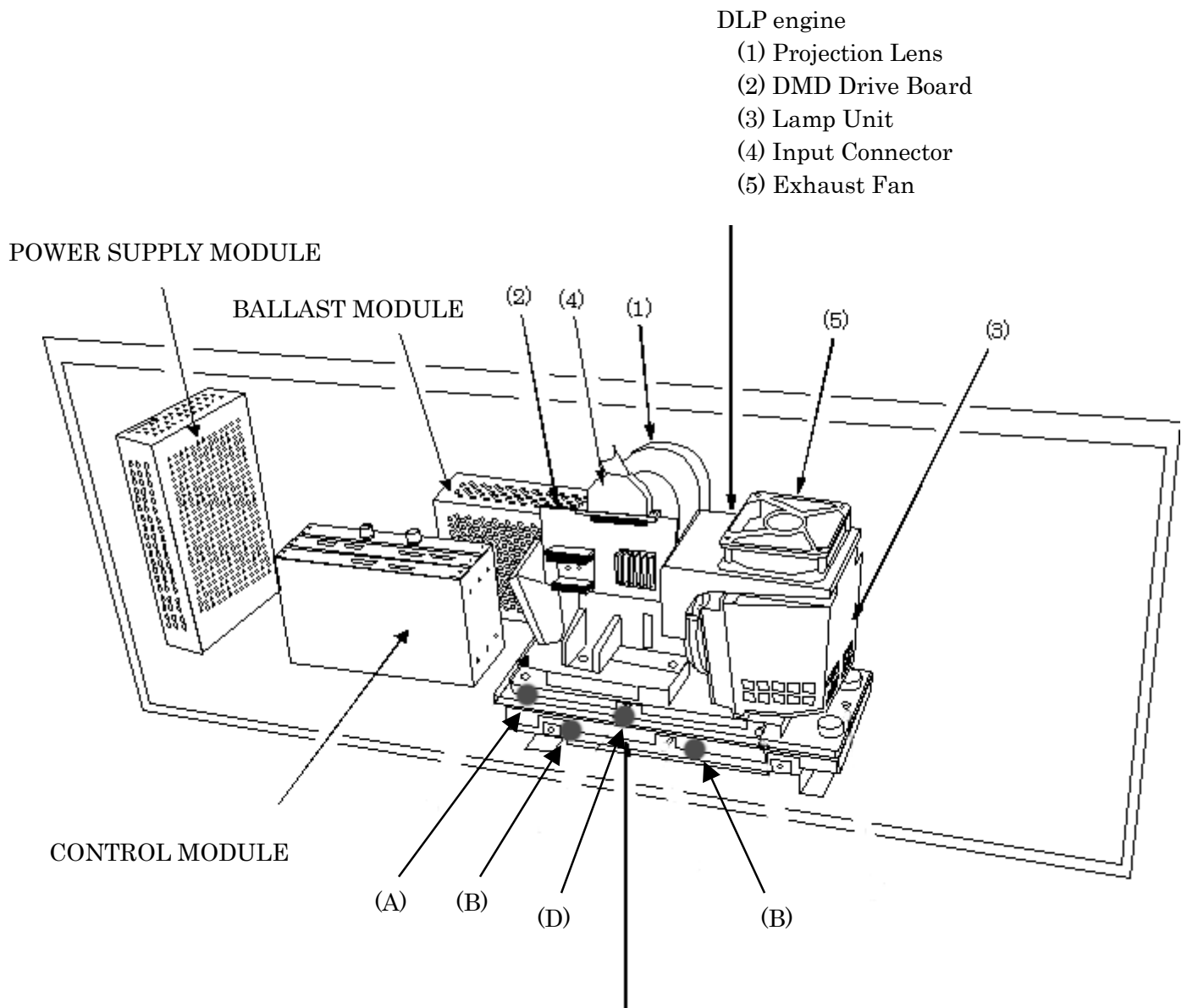

Engine Mount (Adjustment Table)

- (A) Left to Right position adjustment
- (B) Horizontal Tilt, Up/Down adjustment
- (C) Left/Right trapezoid adjustment by Mirror
- (D) Image Size adjustment

3. EXPLODED VIEW OF THE PROJECTION BLOCK

⚠ CAUTION

Be careful to prevent the ESD (Electro Static Discharge) before touching the DLP Engine. If ESD happened, important key components including DMD device may easily damaged. This electro-static destruction will not be covered by Texas Instruments guarantee. For ESD prevention, use conductive wrist strap and connect the wire to the metal frame of the projection engine.

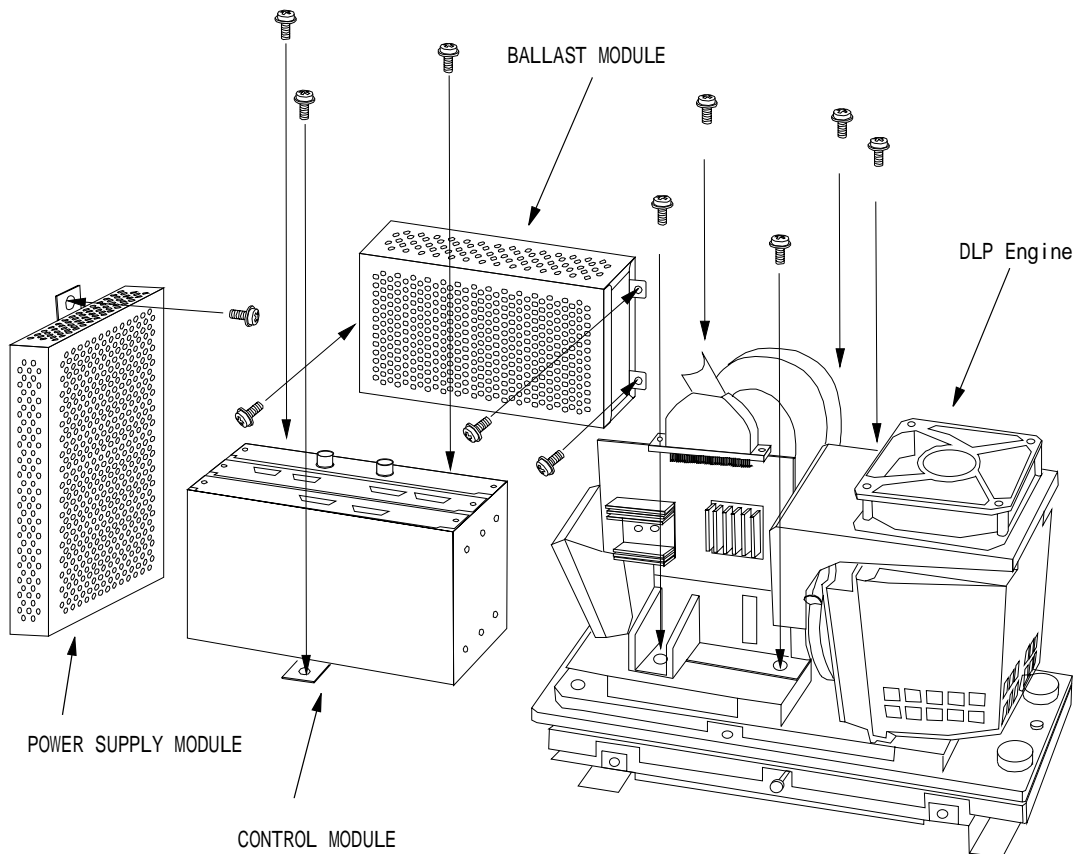

5-1. How to remove the DLP Engine

- 1) Remove 96-pin connector from the DLP engine.
- 2) Remove clock connector from the engine.
- 3) Remove ballast connector from engine.
- 4) Remove 2 screws of lamp power connector from engine.
- 5) Remove 5 screws which are used to tighten engine block and remove engine.

5-2. How to install the DLP Engine

- 1) Place the engine at the right place, locating guide pins to the location holes.
- 2) Tighten 5 screws so that engine will be securely attached.
- 3) By using 2 screws, the lamp connector could be fixed.
- 4) Connect ballast connector to the engine.
- 5) Connect the clock connector to the engine.
- 6) Attach 96-pin connector to the engine, placing correct direction/position of it.

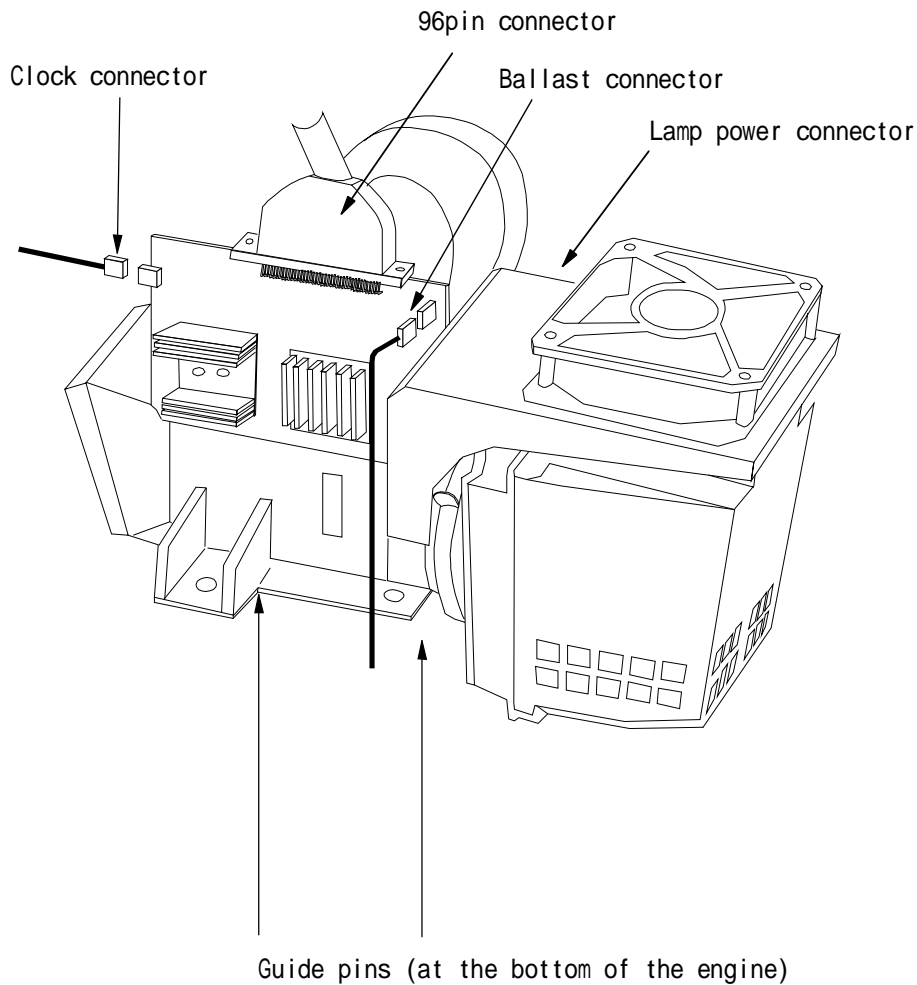

6 . EXPLODED VIEW OF THE SCREEN BLOCK AND CABINET

How to remove the screen block

- 1) Rotate two screen locks and unlock the screen.
- 2) Pull up the Tab at both sides as figure shows.
- 3) Pull the screen block, holding Pull Tabs, so that screen frame can be removed.

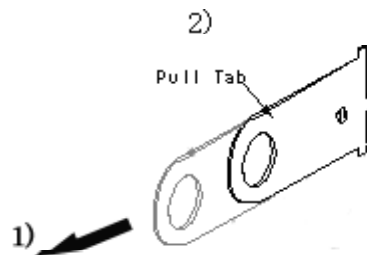
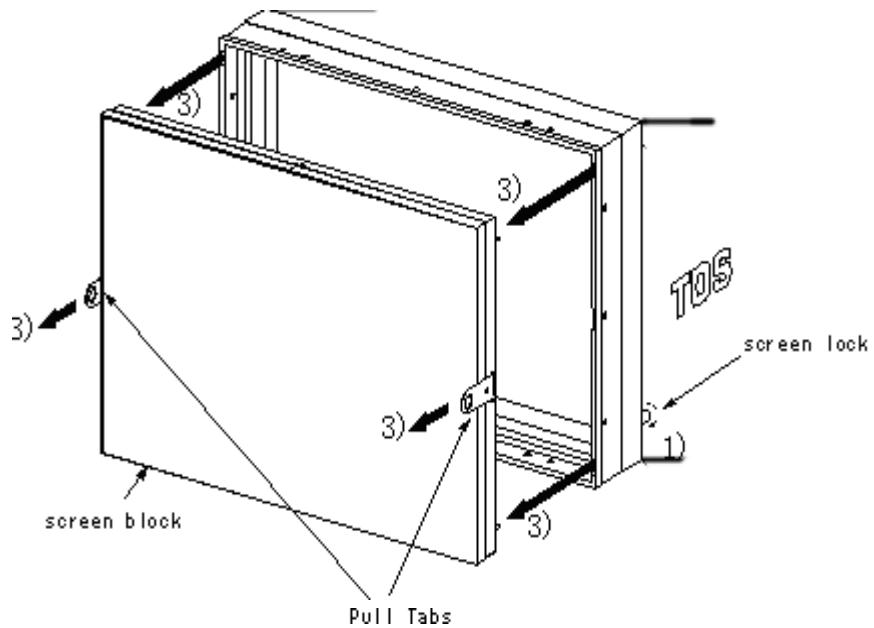

7 . WIRING

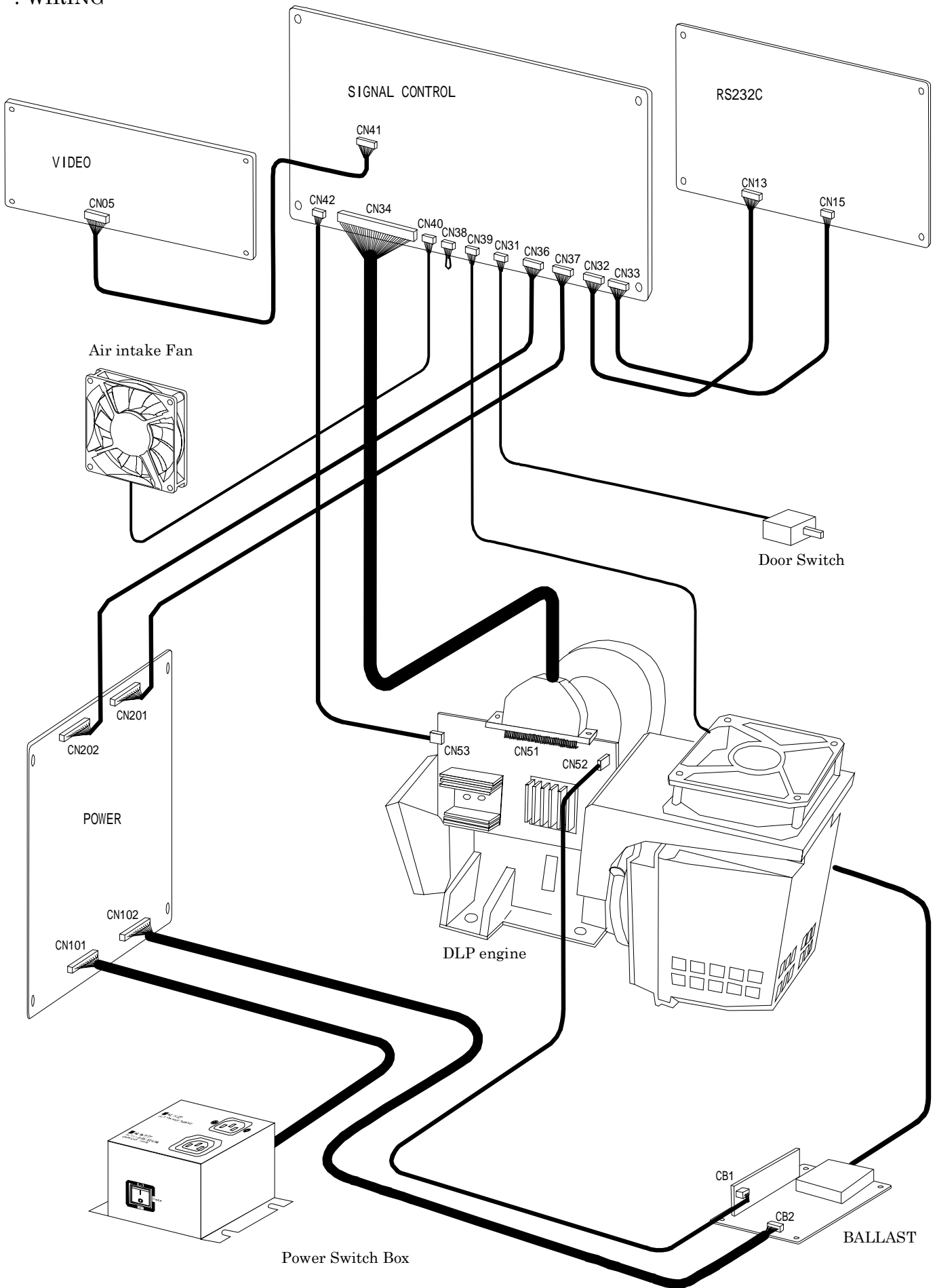

ADJUSTMENT

1. DLP Engine adjustment

When DLP Engine is replaced, most of occasion, following adjustments are needed.
New DLP engine may have some position displacement. The engine mount base has limited adjustment range so that optical engine need to be perfectly adjusted.

1) Adjust the engine mount to the proper positions

By rotating the screw and , obtain 10mm of clearance between base and adjusting platform.

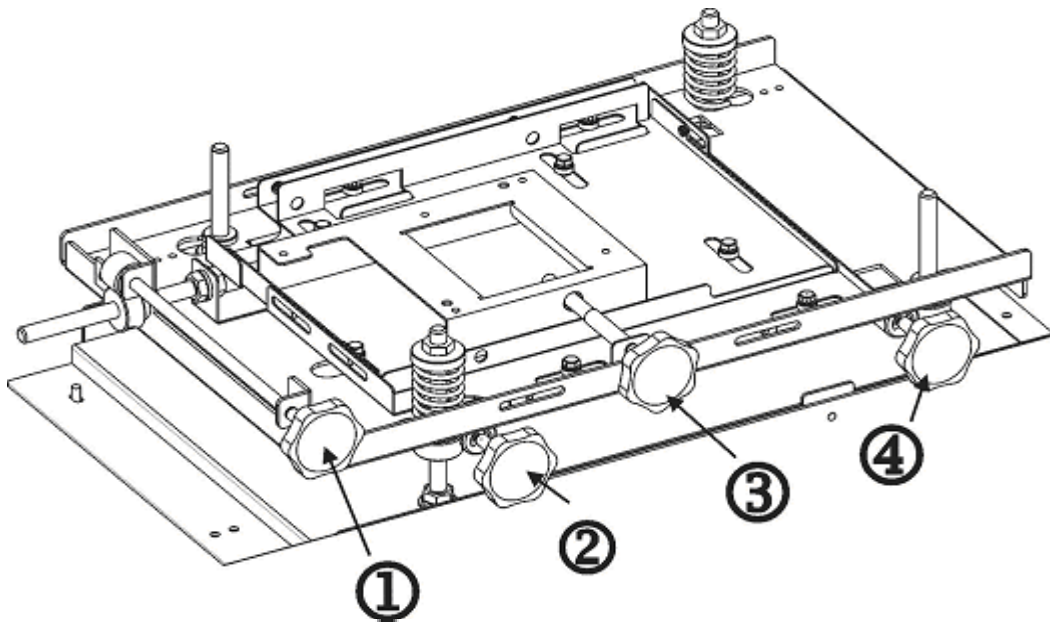

2) Place the engine on the engine mount

Place the engine on the mount and connect all the connectors.

3) Adjust lens focus

- (1) Loosen Focus Ring fastening screw knob and rotate it to have the best focus.
- (2) After the adjustment, tighten the screw so that Focus ring will not move by vibration.

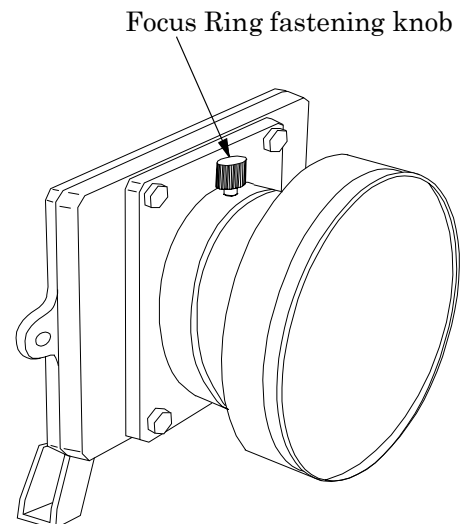

2 . ENGINE MOUNT ADJUSTMENT

1).Use internal test signal, refer to page 28, TEST.P #02, thus full frame image appears on the screen

2). Adjusting Picture Horizontal Position

Rotate knob to adjust Picture Horizontal Position

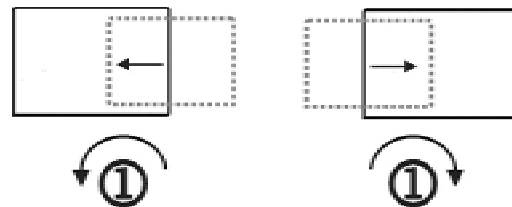
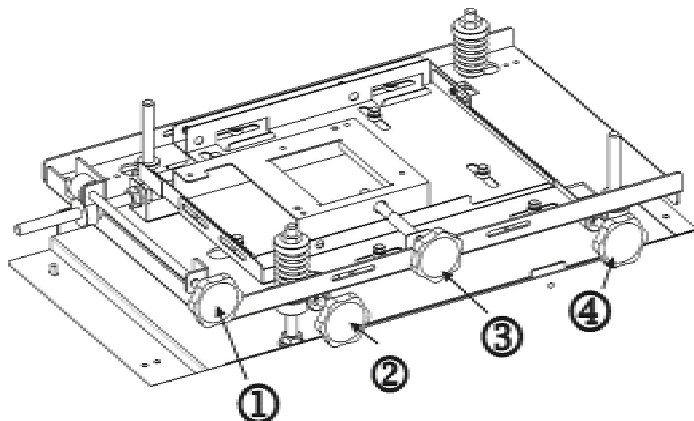

3). Adjusting Picture Rotation

Rotate the adjustment wheel to adjust picture rotation.

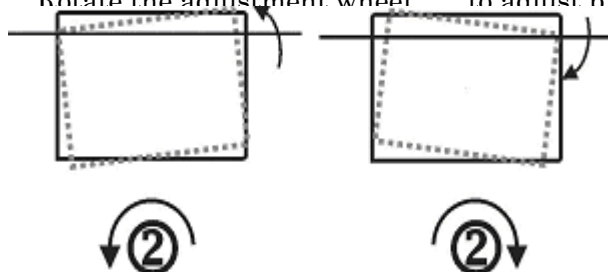

Faster Rotation

Rotate both and wheels to rotate the picture much faster.

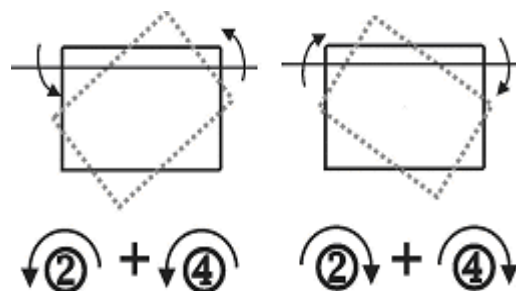

4).Adjusting Picture Size

Rotate knob to adjust the Picture size.

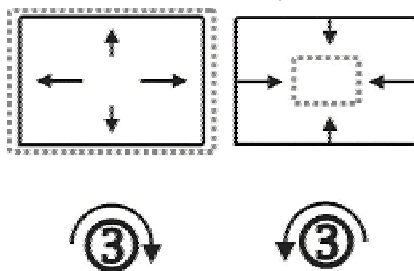

5). Adjust Picture Vertical Position

Rotate the adjustment wheels and of both sides together to adjust the picture vertical position.

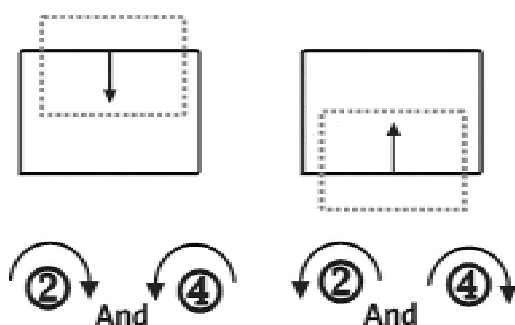

6) Top to Bottom Trapezoid can be compensated by a primary mirror.

Picture Distortion Adjustment

Rotate 1,2,3 to minimize picture distortion.

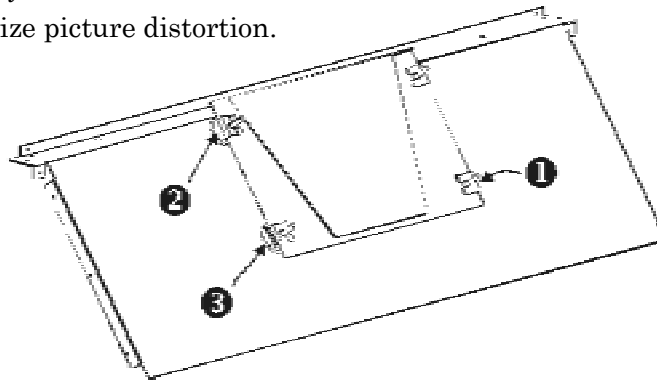

1. When rotate 1, Picture will become as below: 2. When rotate 2, Picture will become as below:



3. When rotate 3, Picture will become as below:

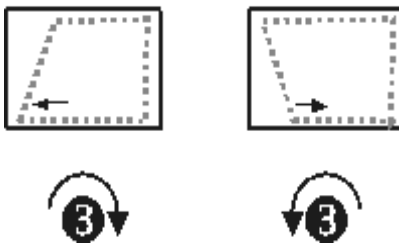

Important Notice:

Do not exceed the adjustment too much, mechanism comes to the end of its adjustment area, there is no stopper mechanism provided and further forcing to do so will make fatal damage to the mechanism.

In such case, Lens Mount Position needs to be corrected at right position.

3. Electronics Adjustment or Setting

Selection or adjustment can be performed using optional Remote Control, model CT-90000 or no obligation, user-risk freeware, 'Cube Commander'.

Remote control CT-9956 (for CRT cubes) can also be used even though the keys are labeled differently - please refer to the diagram below.

Not all keys are used for adjustment.

Connect the remote control to the REMOTE jack on the projector.

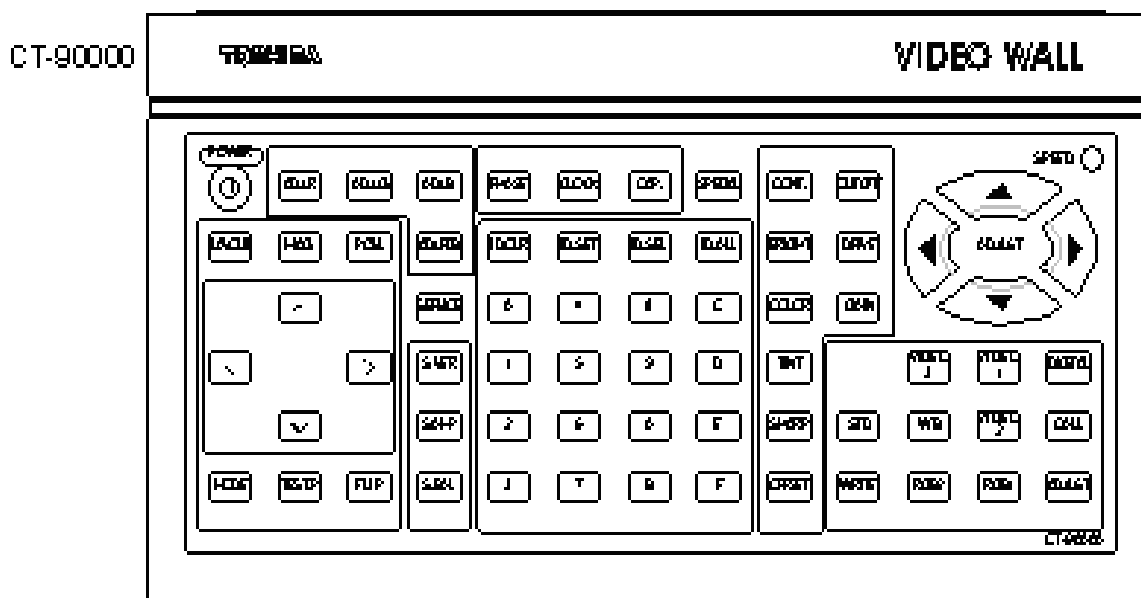

3-1. Input Signal selection

Sources are selected by pressing the relevant source button: **RGB1**, **RGB2**, **VIDEO** or **DIGITAL**. The screen will mute for approximately 5-7 seconds following source selection.

Source selection is only possible in Normal Mode.

(To change sources in Adjust Mode it is necessary to press the **MODE** button first)

3-2. Adjust Mode

Press **ADJUST** to enter Adjust Mode.

To exit Adjust Mode press **ADJUST** twice (one press will request confirmation that you wish to exit Adjust Mode).

3-3. Saving adjustments

Pressing **WRITING** will exit Adjust Mode and save any adjustments made to non-volatile memory.

3-4. Adjustment parameters

All parameters except 'Layout' can be adjusted using the **▲** **▼** **◀** **▶** buttons.

'Layout' position is adjusted using the **⤴** **⤵** **⤶** **⤷** buttons.

3-5. Internal Test Pattern

Test Patterns can be accessed by pressing **TEST.P** in Adjust Mode.

Continuously pressing **TEST.P** button will cycle through the available patterns or individual patterns can be selected by entering the relevant two digit number.

3-6. White Balance adjustment

There are three independent memories for white balance adjustments, press WB in NORMAL mode to select the desired memory (WB1, WB2, WB3) before making adjustments.

There are two stages for white balance adjustment to allow adjustment of low-level and high-level portions of the image.

For low-level adjustment 10-20% IRE signal is required and this should be provided by the main source to be used (i.e. if video is the main source a video test pattern generator should be used and if computer is the main source test pattern software should be used).

BRIGHTNESS will control the overall brightness of the image (not available for DIGITAL input) and **CUTOFF** followed by **ADJ.R**, **ADJ.G** and **ADJ.B** can be used to adjust the relative intensities of red, green and blue.

For high-level adjustment 70-80-90% IRE signal is required.

CONTRAST will control the overall level of the image (not available for DIGITAL input) and **DRIVE** followed by **ADJ.R**, **ADJ.G** and **ADJ.B** can be used to adjust the relative intensities of red, green and blue.

3-7. Gain and Off-Set

The above adjustments act on the digital signal (after the A/D converter) and assume a signal level of 0.7V p-p.

It is also possible to adjust the analogue signal (before the A/D converter) but these adjustments should be kept to the default values in most cases.

OFFSET followed by **ADJ.R**, **ADJ.G** and **ADJ.B** can be used for the low-level adjustment and **GAIN** followed by **ADJ.R**, **ADJ.G** and **ADJ.B** for the high-level adjustment.

3-8. Clock frequency adjustment and phase adjustment

Supply fine pitch signal (such as Windows shut-down screen) and adjust **CLOCK** and **PHASE** to eliminate moiré and jitter.

3-9. Image position adjustment

Initially image position should be adjusted using the mechanical adjustments so that all unmagnified images appear at the same position. Use **POS1** to electronically shift the image and **CAP** to select the position of the image for magnification.

3-10. Screen Mode Selection

Incoming signals are automatically synchronized and the relevant timing data is stored in memory so that this data can be read out each time a particular source is recognized. RGB1 and RGB2 settings are memorized separately. There are a total of 10 memory areas available, if additional frequencies are supplied the earlier settings will be lost.

Auto-adjustment can be switched on or off by pressing **SPECIAL** and then **1**

3-11. On-Screen-Display, OSD

The default condition is for the OSD to be on, this can be switched off by pressing the **CALL** button in Adjust Mode.

It is possible to change the color of the OSD:

SPECIAL **A** = red, **SPECIAL** **B** = green, **SPECIAL** **C** = blue, **SPECIAL** **8** = white.

3-12. Video Enhancer

When video input is selected the following adjustments are available: **COLOUR** , **TINT** (NTSC only) and **SHARP**

3-13. Interpolation Filter

Filtering can be switched on and off by pressing **SERVICE** and then **4**

3-14. Image direction

The image orientation can be flipped up, down, left and right using the **FLIP** key.

3-15. Status Indication

Pressing **CALL** in Normal Mode will display general information such input selection and source frequency.

Pressing **SPECIAL** and then **D** in Adjust Mode will display software version and date.

SPECIAL **F** will display the lamp timer and **SPECIAL** **E** will display lamp history.

3-16. Power ON delay

This can be set in intervals of 0.5secs by pressing **SPECIAL** **9**

4. Multiple Screen Wall system (example)

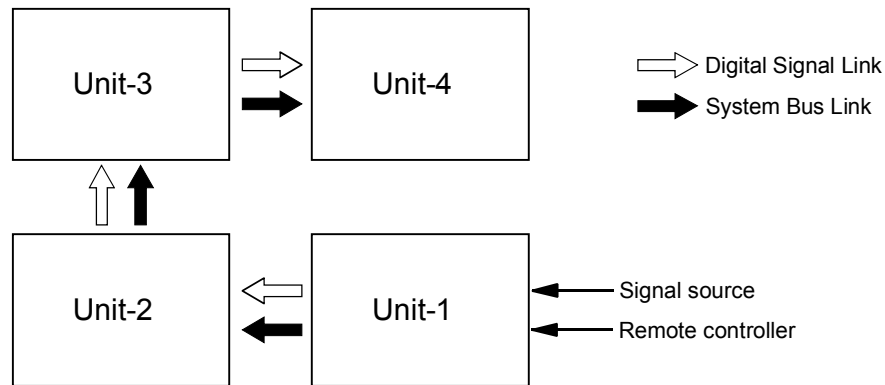

5. ID Assignment (example)

ID# should be assigned before connecting the RS232C control cables and ID# must be cleared before they can be re-assigned.

5-1. Clearing I.D.

Press **ADJUST** to enter Adjust Mode and then press **ID.ALL** to enter I.D. Mode, press **ID.SEL** 3 times and then press **ID.CLR** to erase the current I.D.

5-2. Setting I.D.

Press **ID.ALL** so that 'INPUT ID NUMBER' appears and enter the desired 2 digit I.D. using the alpha-numeric keys. Press **ID.SEL** 3 times and then **ID.SET**, to assign the I.D. – the OSD will disappear and the unit will return to Normal Mode.

5-3 Selecting I.D.

If using Cube Commander software simply select the two digit I.D. for the cube you wish to control.

If using remote control it is necessary to press ID.SEL to access the correct menu for I.D. selection and control.

If **ID.ALL** is pressed instead of an alpha-numeric key 'X' will appear, pressing **ID.ALL** twice will display 'XX' which will allow control of all units simultaneously.

6. Magnification

To magnify the image repeatedly press **MAG** in Adjust Mode to change the magnification factor 1x1, 2x2, 3x3... It is also possible to select the magnification factor using the numeric keys so that magnifications such as 1x2, 2x3, 4x3 etc can be selected.

Once the desired magnification has been selected press **LAYOUT** followed by **▲** **▼** **◀** **▶** to select the portion of the image to be displayed.

1. RGB/Control PCB

Input signals RGB1 and RGB2 are switched by analogue RGB switch IC, ADG774.

VIDEO input is decoded by VPC3230D, auto-switching between PAL and NTSC, the output is 16 bit 4:2:2 YUV.

DIGITAL signal is supplied to SII151, single link DVI receiver.

Analogue signals are then converted to digital by A-D converter is AD9884.

The digital signal is supplied to the frequency converter scaler PW164.

The functions of PW164 scaler IC are:

- Auto-detect 48-bit RGB signal display timing
- Auto-adjust capture, position, signal clock and phase
- Auto-capture video 16 bit YUV signal
- Image scaling up/down (VGA, SVGA, SXGA to XGA)
- Frame rate conversion with frame buffer memory
- Video YUV color space conversion
- Test pattern OSD generation
- On-chip 16 bit MPU for software development
- DMD control signal generation
- Digital 24 bit RGB, XGA outputs

Incoming signals are all converted to XGA, 60Hz

Signal recognition and scaling is carried out using standard VESA signals, if a non-standard signal is supplied the image may not be displayed correctly.

All incoming signals are converted to 60Hz and the color filter rotation speed is 120Hz.

The output from the scaler is supplied to the magnification scaler, GmZ4S and this IC is controlled by MCU8051.

2. DMD Driver PCB

The processed digital signal is sent from the RGB/Control PCB to the DMD Driver PCB via the 96-pin digital signal cable. The TI driver IC controls to signal supplied to the DMD through frame memory buffers.

3. Power Supply PCB

The power supply consists of two sections, Power Factor Control and DC-DC conversion.

Incoming AC is rectified and supplied to the PFC converter where the resulting power factor is 1.

The output of the PFC circuit is 370V DC and this is supplied to the main and standby DC-DC converters and also the Lamp Ballast.

The outputs of the main DC-DC converter are +12V and +4V, the outputs of the standby DC-DC converter are +12V and +5V.

Over-voltage protection is triggered when the +4V supply rises above +6.3V. SCR201 is controlled by ZD201 and this triggers the protection circuit.

Short circuit protection of the +12V and +4V lines is monitored by IC101 pin3 and the +12V and +5V standby lines are monitored by IC104 pin5

4. Lamp Ballast PCB

The Philips® 120W UHP lamp is driven by Philips ballast power supply, input voltage is 370V DC and high voltage trigger and lamp supplies are output.

5. RS232C Control PCB

RS232C control signals and remote control from optional CT90000 are accepted, if both are connected CT90000 has priority.

6. Video PCB

Accepts PAL/NTSC composite video signal and has a buffered output for loop-through.

P600DL control board LED status

12-11-2001 Ver. 0.9

	POWER	FAN	LAMP	Blink time	
POWER ON STANBY	● off	●	●		
	● red	●	●		
POWER ON	● grn	●	●		Before Lamp lights
	●	●	●		After Lamp lights
FAN STOP	●	●	●		
	●	★	●	0.2 SEC	Lamp shutdown
Lamp cannot light	●	●	●		
Lamp Broken	●	●	★	0.2 SEC	
Interlock	●	●	★	0.5 SEC	
FAN NG	●	★	●	0.2 SEC	Before Lamp lights
STANBY	●	●	●		
	★ red	●	●	0.5 SEC	Lamp shutdown
	● red	●	●		STANBY
Temperature abnormal	●	●	●		Thermal sensor

The star indications are showing that the lamp blinks.

Control via RS-232C – Command Protocol list

Table –1 RS-232C pin-connection configuration

Pin No	Signal name	Signal items	I/O (in projector)
1	CD	Not used	-
2	RXD	Reception data	Output
3	TXD	Transmission data	Input
4	DTR*	Data terminal ready	Input
5	SG	Signal ground	-
6	DSR*	Data set ready	Output
7	RTS**	Transmission request	Input
8	CTS**	Transmission enable	Output
9	CI	Not used	-

* Shorted at projector inside ** Shorted at projector inside

Table –2 RS-232C Communication status

Status name	Status
Communication system	Transmission speed : 9600bps Parity bit : NO, Data length : 8 bit, Stop bit : 1 bit
Communication type	1 Block consists of STX (1Byte) + IDT(2Byte) + CMD (3Byte) + ETX (1Byte). STX=02h, ETX=03h, IDT= Alphanumeric character

2-2-3 Control Commands List:

Table : 1 Standby mode (Command to be used in standby mode)









Item	Contents	Key(CMD**)			
POWER	Turning power ON	PWR	PON		

PWR: Alternation switch command PON: Direct switch command

Table : 2 Normal mode (Command to be used in normal mode)

Item	Contents	Key(CMD**)			
POWER	Switch projector to power on or off state	PWR	POF		
CALL	Show status on the screen, on and off	DSP	DON	DOF	
RGB1	Selects RGB – 1 input source		IN1		
RGB2	Selects RGB – 2 input source		IN2		
DIGITAL	Selects DIGITAL LINK input source		IN3		
VIDEO	Selects VIDEO input source		IN4		
W/B	Switch white balance mode (W/B)	WBL	WB1	WB2	WB3
ADJUST	Enters adjustment mode (ADJUST/MODE)	AJS	AJY		
ID SET	Setting ID		IDS		
	Picture mute on or off	MSW	MON	MOF	

Table : 3 ADJUST MODE (Command to be used in ADJUST MODE)

Item	Contents	Key(CMD**)		
CONT.	Selects contrast adjustment (ADC RGB gains)		CNT	
BRIGHT	Selects brightness adjustment (ADC RGB offset)		BRT	
COLOR	Selects color adjustment (Video decoder)		COL	
TINT	Selects tint adjustment (Video decoder)		TNT	
SHARP	Selects picture sharpness adjustment (video decoder)		SHP	
CUTOFF	Selects DLP brightness adjustment mode (white balance D, Dark)		LOW	
DRIVE	Selects DLP contrast adjustment mode (white balance B)		HIG	
GAIN	Selects gain adjustment (ADC RGB separate Gain)		GAN	
OFFSET	Selects offset adjustment (ADC RGB separate Offset)		OFS	
FLIP	Switch image direction (1.2.3.4)		FLP	
POSI.	Selects display position pixel base adjustment (Z4)		POS	
CLOCK	Selects sampling clock frequency adjustment		CLK	
PHASE	Selects sampling clock phase adjustment mode		PHS	
CAP.	Selects caption position adjustment mode (PW)		CAP	
MAG.	Switches screen magnification (1x1 - 6x6)	MAG		
LAYOUT	Selects screen layout selection mode		LAY	
TEST.P	Selects internal test pattern (PW)	TSP		
ADJ.R	Selects adjustment color Red		SLR	
ADJ.G	Selects adjustment color Green		SLG	
ADJ.B	Selects adjustment color Blue		SLB	
ADJ.RGB	Selects adjustment color red +Green + Blue		SLA	
	Adjusts movement to up or data value increase		VUP	
	Adjusts movement to down or data value decrease		VDW	
	Adjusts movement to left		VLF	
	Adjusts movement to right		VRG	
	Change layer upward (uses in LAYOUT selection mode) or test pattern number decrease (uses in TEST. Mode)		DUP	
	Change layer downward (uses in LAYOUT selection mode) or test pattern number increase (uses in TEST. Mode)		DDW	
	Changes layout leftward (uses in LAYOUT selection mode)		DLF	
	Changes layout rightward (uses in LAYOUT selection mode)		DRG	
CALL	On screen display status or menu on or off	DSP	DOD	DOF
WRITE	Memorizing adjusted data		VWR	
SERVICE	Entering SERVICE MODE		SVC	
SPECIAL	Entering SPECIAL MODE		SPC	
ID.ALL	Entering ID MODE		IDA	
ADJUST	Exits ADJUST MODE (return to normal mode)	AJS	AJN	
MODE	Enable INPUT SOURCE SWITCH in ADJUST mode		MOD	
AutoAdjust	Execute Auto-adjust		AUT	
SPEED	Select Baud Rate		SPD	
0	Input 0		VN0	
1	Input 1		VN1	

2	Input 2		VN2		
3	Input 3		VN3		
4	Input 4		VN4		
5	Input 5		VN5		
6	Input 6		VN6		
7	Input 7		VN7		
8	Input 8		VN8		
9	Input 9		VN9		

Table 4 : SERVICE MODE (Command to be in SERVICE MODE)

Item	Contents	Key(CMD**)			
1	Switches OSD mute on or off	VN1			
4	Switches interpolation filter (A, B, C, D, E)	VN4			
WRITE	Memories adjusted data		VWR		
CALL	ON screen menu on or off	DSP	DON	DOF	
ADJUST	Exits SERVICE MODE (return to ADJUST MODE)	AJS	AJY		

Table 5 : SPECIAL MODE (Command to be used in SPECIAL MODE)

Item	Contents	Key(CMD**)			
0	Clear lamp history memory		RA0		
1					
2					
3					
4					
5					
6					
7					
8	OSD color change to white(default)		RA8		
9	Set power on delay from 0 to 4.5 seconds		RA9		
A	Change OSD color to red		RAA		
B	Change OSD color to green		RAB		
C	Change OSD color to blue		RAC		
D	Display Software Version		RAD		
E	Display elapse time and lamp replacement history		RAE		
F	Display lamp timer		RAF		
STD	Resetting present lamp timer (uses after F if necessary)		VST		
WRITE	Memorizes adjusted data		VWR		
CALL	Onscreen display on or off	DSP	DON	DOF	
ADJUST	Exits SPECIAL MODE (return to ADJUST MODE)	AJS	AJY		

Table 6 : ID MODE (Command to be used in ID MODE)

Item	Contents	Key(CMD**)		
ID.CLR	Clearing ID		IDC	
ID.SET	Setting ID		IDS	
ID.ALL	Input *		IDA	
0	Input 0		VN0	
1	Input 1		VN1	
2	Input 2		VN2	
3	Input 3		VN3	
4	Input 4		VN4	
5	Input 5		VN5	
6	Input 6		VN6	
7	Input 7		VN7	
8	Input 8		VN8	
9	Input 9		VN9	
A	Input A		VNA	
B	Input B		VNB	
C	Input C		VNC	
D	Input D		VND	
E	Input E		VNE	
F	Input F		VNF	
ADJUST	Exits ID MODE (return to ADJUST MODE)	AJS	AJY	
ID.SEL	Select ID		IDT	

DMD DRIVER BOARD DEBUG

1. Check power voltage
 - (1) Check U93 PIN2=3.3V
 - (2) Check U94 PIN3=+5V
 - (3) Check CN51 PIN23,24,47,48=12V
 - (4) Check Q102 PIN2,4=32V
 - (5) Check C591 Negative=-32V
2. Check echo IC work frequency
 - (1) check X9 PIN3=58MHZ
 - (2) check U72A PIN2=14MHZ
 - (3) check U91A PIN2=9.667MHZ
3. Check control signal
 - (1) Check CN51 PIN93(PWRGOOD)=3.3V (High active)
 - (2) Check CN51 PIN91(RESETDMD)=3.3V (High active)

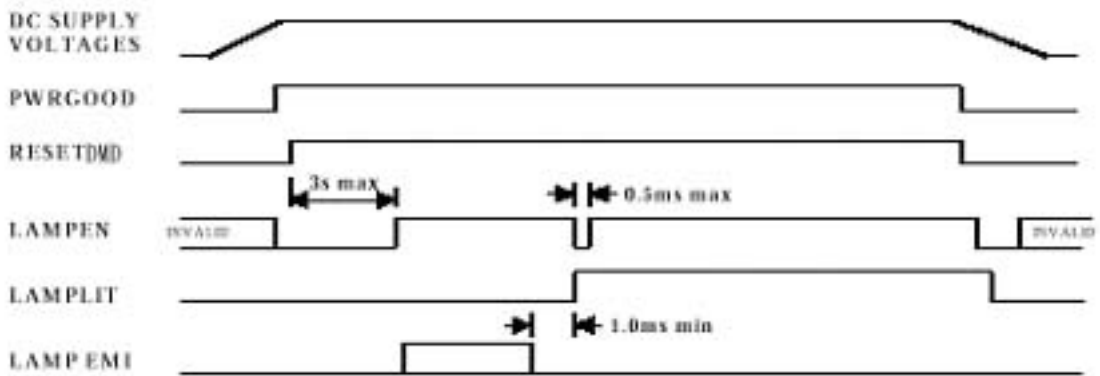
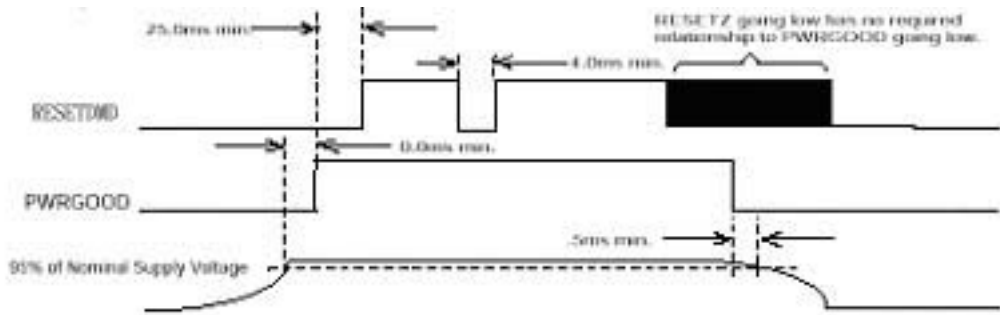

(3) Verify HSYNCZ, VSYNCZ, ACTDATA, SYNCVALID(HI Active) control signal

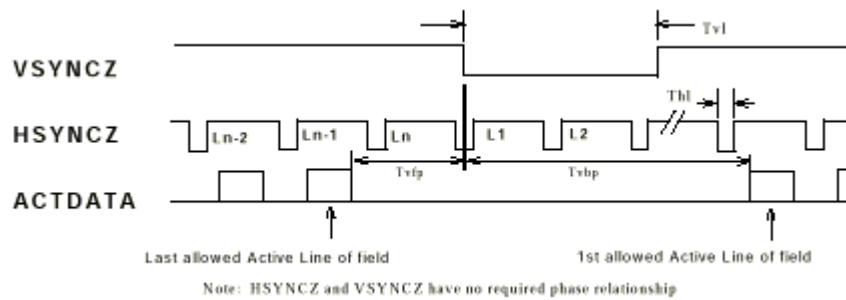

4. Verify U74A PIN1 Running at 120HZ. If no color wheel spinning, check U71 data transfer on the following line MTRDATA, MTRCLK, MTRSELZ.

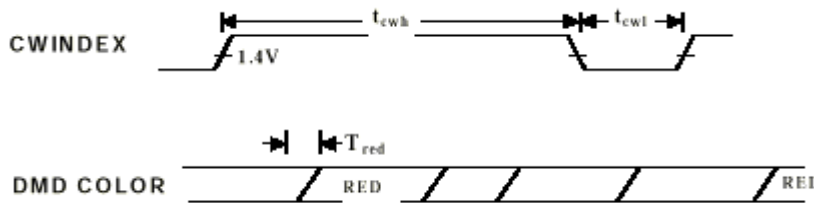

5. Verify motor spinning line from micro-controller U71 (PIN51) to FPGA(U76 PIN 126) is Hi.
6. Verify hardware LAMPEN (U76 PIN168) is Hi (3.3v).
7. Check LAMPLIT is Hi.
8. If everything else verified, but still no image, perform the following check
 - (1) Check DMD voltage at output of generation circuits, but also out of U88 (DMDSR16) IC (be careful not to probe on pins r the device could be damaged) VBIAS(22-25V), VRESET(-26V), VCC2(7.5V).
 - (2) Check voltage enable form FPGA are active as appropriate. If not, output Driver may be blown from previous probing.
 - (3) Be sure two reset lines are not tied together or the device will be damaged.
 - (4) Verify I²C communication by reading system status and micro-controller version.
9. Be sure front end electronics are sending one pixel per clock.
10. Elastomer and DMD are aligned properly to pads.
11. Check data transfer on the following lines: PBCLKZ, PBDAT0, PBDAT1.
12. If Color wheel has difficulty in starting or is unstable, the capacitors may need to be adjusted to match the motor parameter.

DMD DRIVER BOARD Debugging Flow Diagram

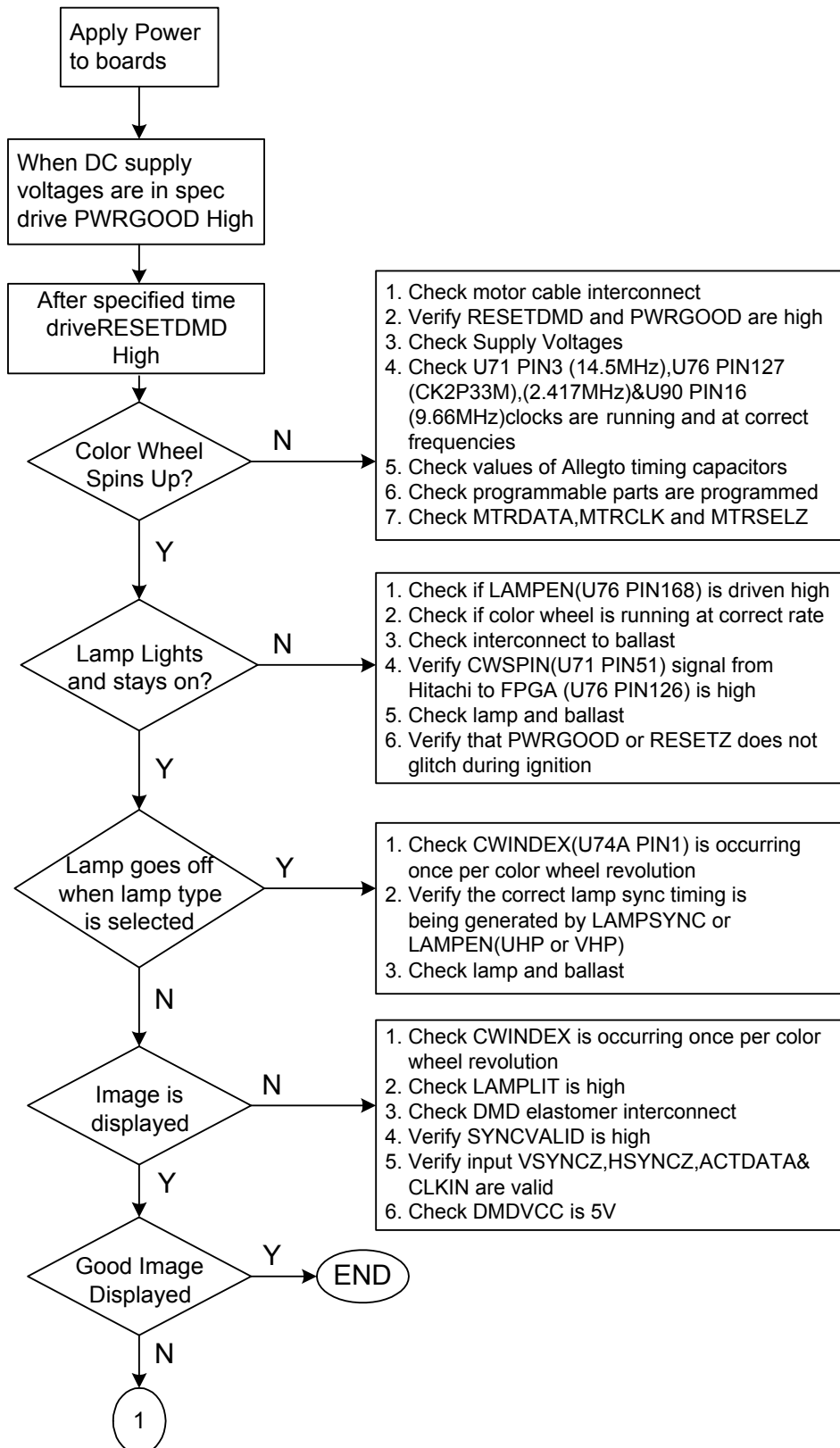

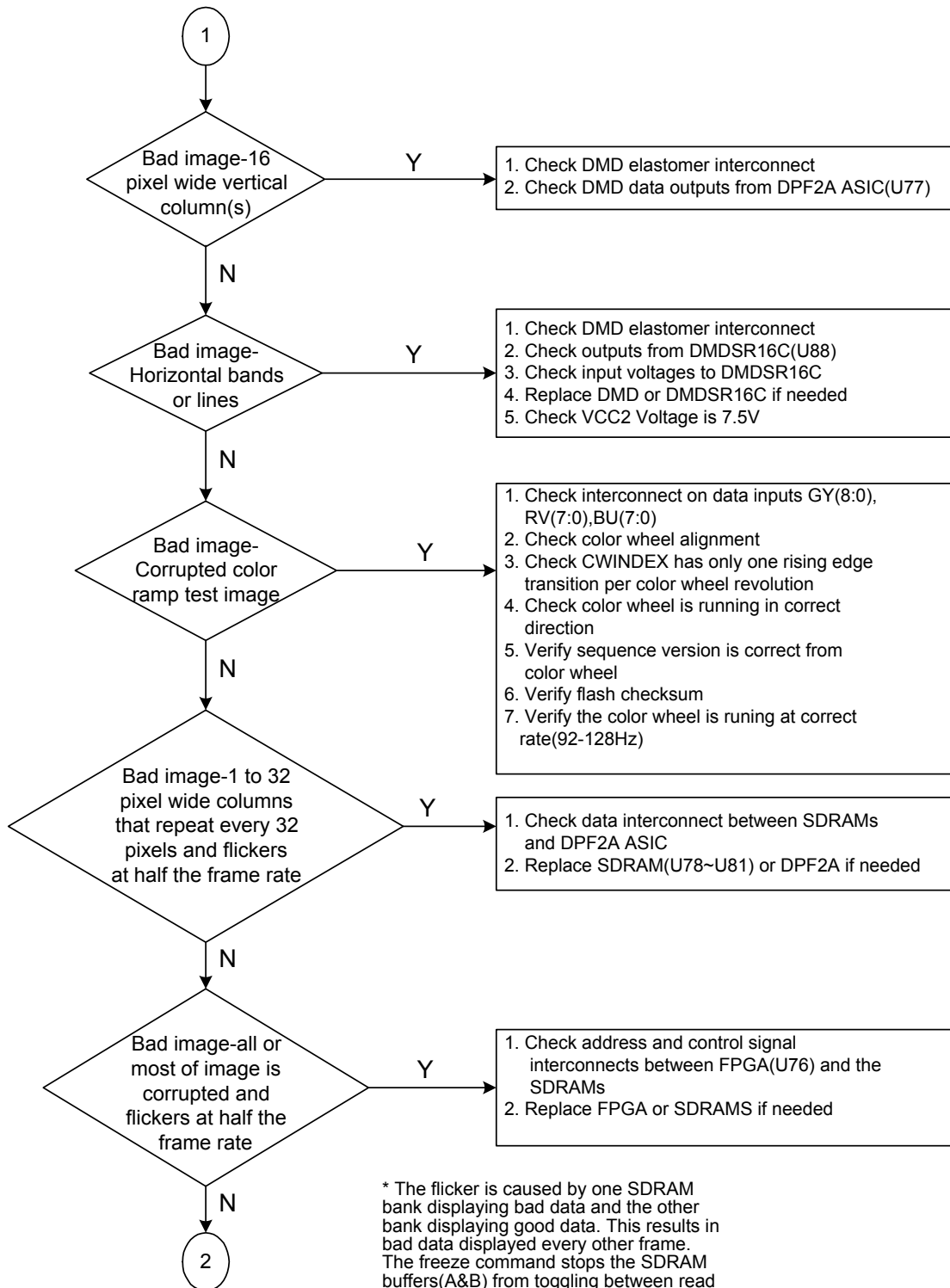

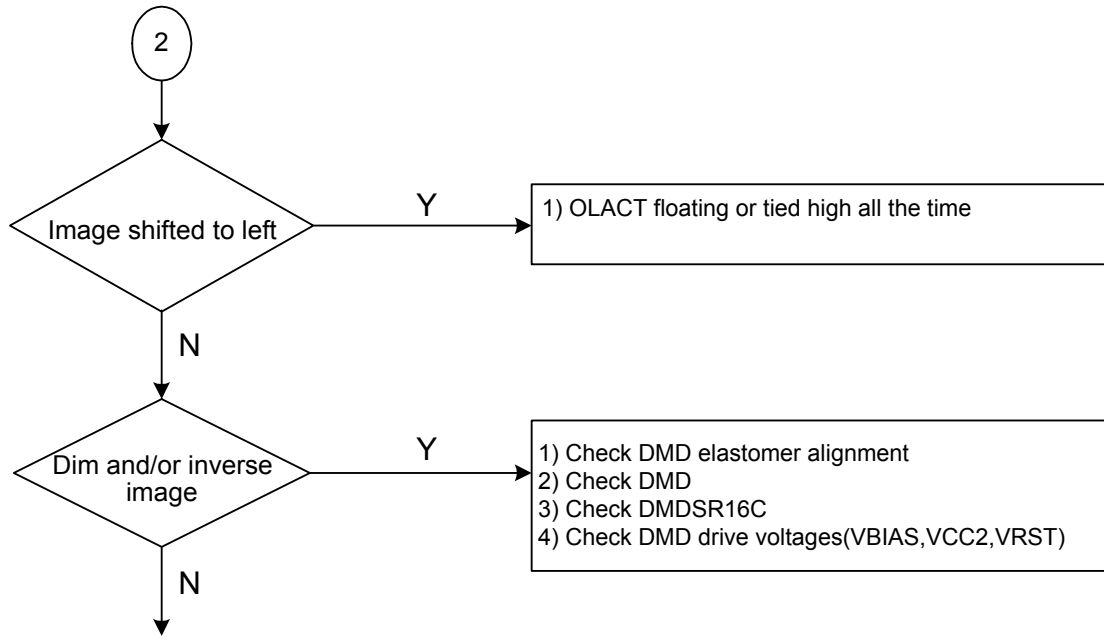

PARTS LIST

Location No	P/N	Description
A101	P600CABINTE	CABINET, P500DL CABINET K
A102	P600SCREEN	SCREEN KUMITATEHIN P500DL
A104	P600SC	SCRCREEN P500DL
A021	P600TILT	ADJUSTER, TILT DAI
A701	P600CARTON	CARTON, CASE
A702	P600PACK	PACKING, PACKIGN 1-SHIKI
A703	P600PHOGO	HOGO SHEET 3000X800 34G7
A704	P600PG63	POLYETHILENE BUKURO G63
A710	P600PCAST	DY PACKING CASE STOPPER
A711	P600PBAND	POLY PROPYLENE BAND
Y101	P600MANUAL	OWNER'S MANUAL, P500DLJ
Y102	P600SCREW	PRODUCTS, SCREW FUZOKUHIN
	94800815	DVI Cable
	94800802	96-pin Data Cable
	94800803	RS232C Cable
	94800804	DC Fan Assy AFB0912H-R00
	94800805	Door Switch
	94800806	Power Module Assy
	94800729	Ballast Module Assy 120W
	P600LAMP	Lamp
	94800808	Color Wheel Assy
	94800809	AC Box Module
	94800810	DMD 0.7" 12 deg SDR
	94800723	Lamp Housing Assy
	94800811	RS232C Board Assy
	94800812	Control Board Assy
	94800814	Video Board Assy
	94800813	DLP Driver Board Assy
	94800761	CT-90000 Wired Remote Control

