



MD1920P4 E-HD 1920 × 1200 LCOS MicroDisplay

PRELIMINARY PRODUCT BRIEF
CONFIDENTIAL
V0.2 dev 11/10/03

OVERVIEW

The MD1920P4 E-HD microdisplay device is a high-resolution Liquid Crystal on Silicon (LCOS) microdisplay optimized for high performance single-panel, dual-panel and triple panel projection applications. The MD1920P4 boasts a high contrast ratio, high brightness, and a very fast LC switching time. This display has been designed for optical engine architectures that require very high refresh rates and 24-bit color. Both field sequential and scrolling color management techniques are supported.

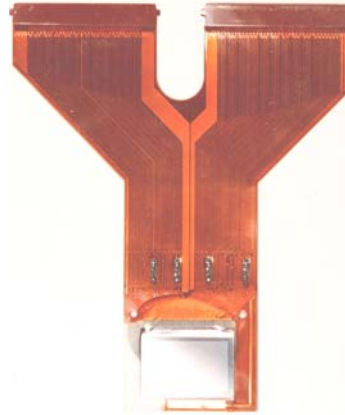

TYPICAL APPLICATIONS

- Rear Projection Televisions
- Front Projectors

ACHIEVABLE DIAGONALS (PIXEL ARRAY)

Resolution	Diagonal
1920 × 1080p	0.81 inch (20.5 mm)
1920 x 1200 Full Array	0.83 inch (21.1 mm)
1920 x 1152 PAL/SECAM HD	0.82 inch (20.8 mm)
1600 × 1200 UXGA	0.73 inch (18.6 mm)

INTERFACE

- Fully digital LVCMOS double-data-rate (DDR) pixel interface
- Parallel 32-pixel raster-order inputs
- Integrated digital-to-analog converters (no voltage offset matching required)
- Massively parallel sampled-ramp digital-to-analog conversion
- Integrated LVDS clock receivers
- Flexible image timing supports custom drive schemes
- Line-wide and array-wide pixel-reset functions ("FlashClear")
- Random vertical addressing
- Supports many color management schemes including simple and super scrolling color

KEY SPECIFICATIONS

Display type	Gray-scale active-matrix liquid-crystal-on-silicon CMOS backplane
Display mode	Reflective, normally white, nematic liquid-crystal material
Grayscale accuracy	24 bits (8 bits per color)
Signal Interface	MicroDisplay PixelPort 2c(MPP2c)
Field rate	60 Hz – 540 Hz
Photopic Reflectivity	~ 61% over F# = 2.8 (full visible spectrum)
Contrast Ratio	~ 600:1 over F# = 2.8 (full visible spectrum, with ContrastCoupler™)
Liquid Crystal Switching Speed	0.15ms 90%-10% (bright to dark) @ 50C 1.0ms 10%-90% (dark to bright) @ 50C
Coating	Anti-reflection coated, R < 0.3% between 420 – 680 nm
Pixel-mirror fill factor	91%
Pixel pitch	9.3µm * 9.3 µm
Dimensions of pixel array	17.86 mm x 11.16 mm
Dimensions of display cell	21.86 mm x 16.49. mm
Supply voltage	12.0 V Analog, 3.3 V Digital
Power Consumption	<400 mW @ 540 fields/sec
Storage temperature	5°C to 60°C

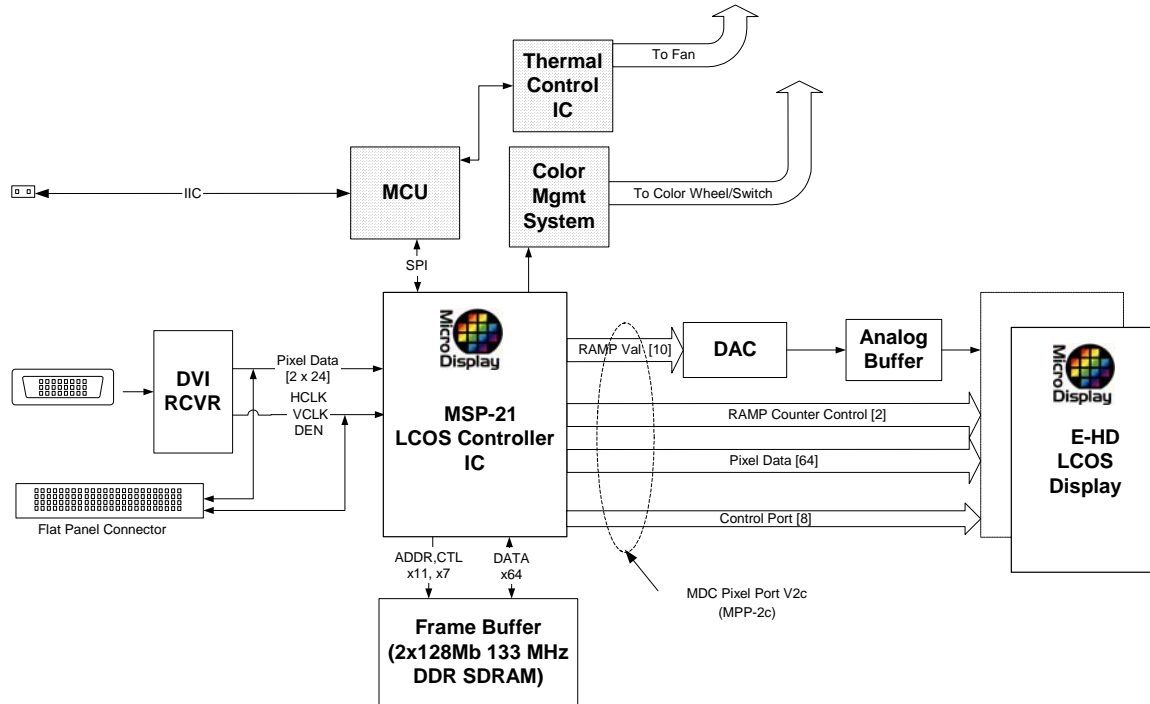

Typical system using the MD1920P4

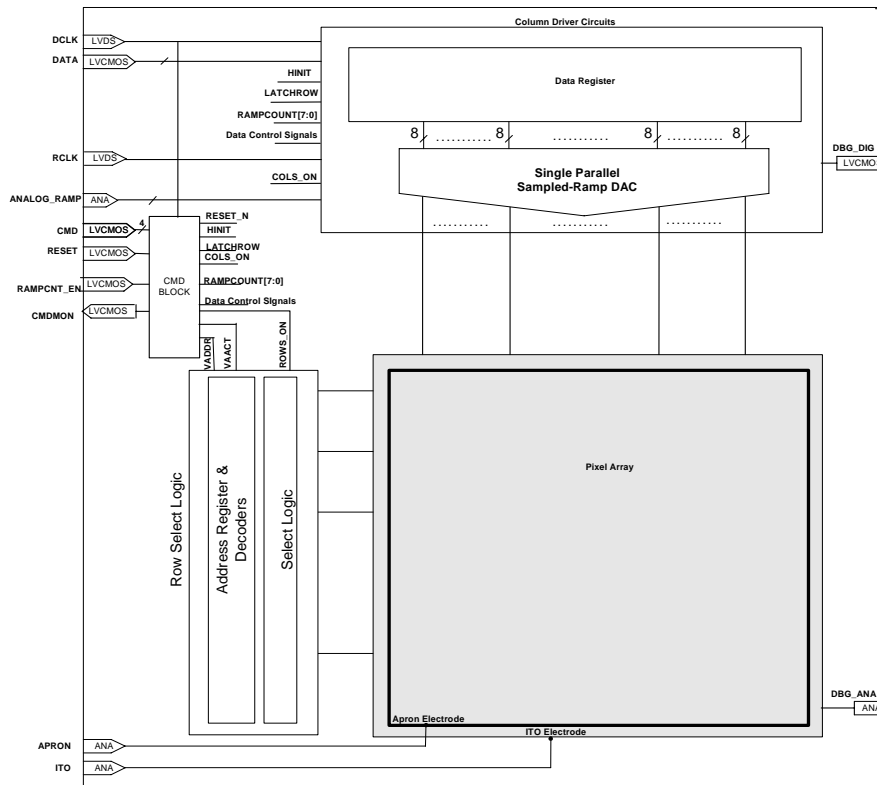

Internal architecture of the MD1920P4