



Lincoln Laser Company
234 East Mohave
Phoenix, AZ 85004

Phone: (602) 257-0407
Fax: (602) 257-0728

<http://www.lincolnlaser.com>
E-Mail: bev@lincolnlaser.com

Application Note #214:
MOTOR/POLYGON SPEED STABILITY DEFINITION
AND MEASUREMENT
10/04/93

DEFINITION

For the discussion herein, having to do with polygon/motor assemblies for use in laser printing machines, the definition of speed stability is:

The repeatability of transit time (T) from point A to point B of the scan of a focused light spot centroid at a photoreceptor, measured as the value of T_{max} minus T_{min} as a percent of $T_{average}$.

GENERAL DISCUSSION

A typical scanner optical system for generating images on a photoreceptor can be described as follows. Intensity modulated laser light is repeatedly deflected by a motor driven multifaceted polygonal mirror. The deflected beams are focussed by a "scan lens" onto the surface of photoreceptor (film, electro-photographic surface, etc). The photoreceptor is transported in a direction at right angles to the scan direction at a rate such to separate scan lines by their width, creating a raster of lines.

The printing machine control electronics provide the modulation signals to the scanner optical system for image creation. Start of scan (SOS) and end of scan (EOS) detectors provide synchronization information back to the controller, so that it knows precisely when to provide the modulation of picture elements (pixels). From the instant that a start of scan pulse is received until a scan line is completed, the system relies on Motor/Polygon speed stability for the accuracy of location of pixels. In other words, the system assumes that no speed instabilities will occur during the scan to dislocate pixels. This assumption is based on specifying a speed stability tolerance.

CAUSES OF SPEED INSTABILITY

There are many elements of the scanner optical/mechanical/electronic complex that have primary and secondary (magnitude) effects on speed stability.

A. Primary Causes

1. Electronic Driver Stability

- Frequency and phase stability
- Voltage stability
- Noise

2. Motor Characteristics

- Hunting (low frequency)
- Cogging (high frequency)
- Dynamic balance (unbalance)

3. Bearing Behaviour

- Varying resistance torque from lube migration
- Roughness from wear and or dirt
- Bearing pre-load

4. Polygonal Mirror Characteristics

- Flatness
- Facet radius uniformity (distance from center of rotation)
- Reflectance uniformity

5. Environmental (external shocks and vibrations)

B. Secondary Causes

1. SOS detector/amplifier noise

2. Facet (polygon) surface roughness

3. Air turbulence in the optical path (high speed systems)

4. Polygon/Motor tracking accuracy

5. Laser pointing errors (dynamic)

This is a long, but certainly not exhaustive, list of causative elements contributing or potentially contributing to speed stability errors. It becomes obvious that the entire scanner optical system is involved and influences the speed stability measurement and result.

LINCOLN LASER'S STANDARD
SPEED STABILITY MEASUREMENT SYSTEM (TDDAS)

TDDAS is an acronym for Two Detector Data Acquisition System. A schematic of TDDAS is attached to this application note. This optical/electronic measurement system provides an output of speed stability values for motor/polygon assemblies which is the basis for "standard specification published or quoted by the company".

TDDAS may or may not be representative of the electro-optic system the customer intends to use a motor/polygon in. If TDDAS is clearly not representative of the "intended use" characteristics, then one of three actions should be taken to assure that the customers expectations are met. These are:

- A. Lincoln Laser and the customer cooperate to develop a correlation chart that will provide accurate and repeatable cross-correlation results of testing by the two companies test methods.
- B. Customer supply a representative electro-optics module for use by Lincoln Laser to test Motor/Polygons for acceptance before shipment.
- C. Lincoln Laser design and construct a test set that incorporates the customers salient design features (and possibly some customer furnished unique parts) to be used exclusively to test customer product.

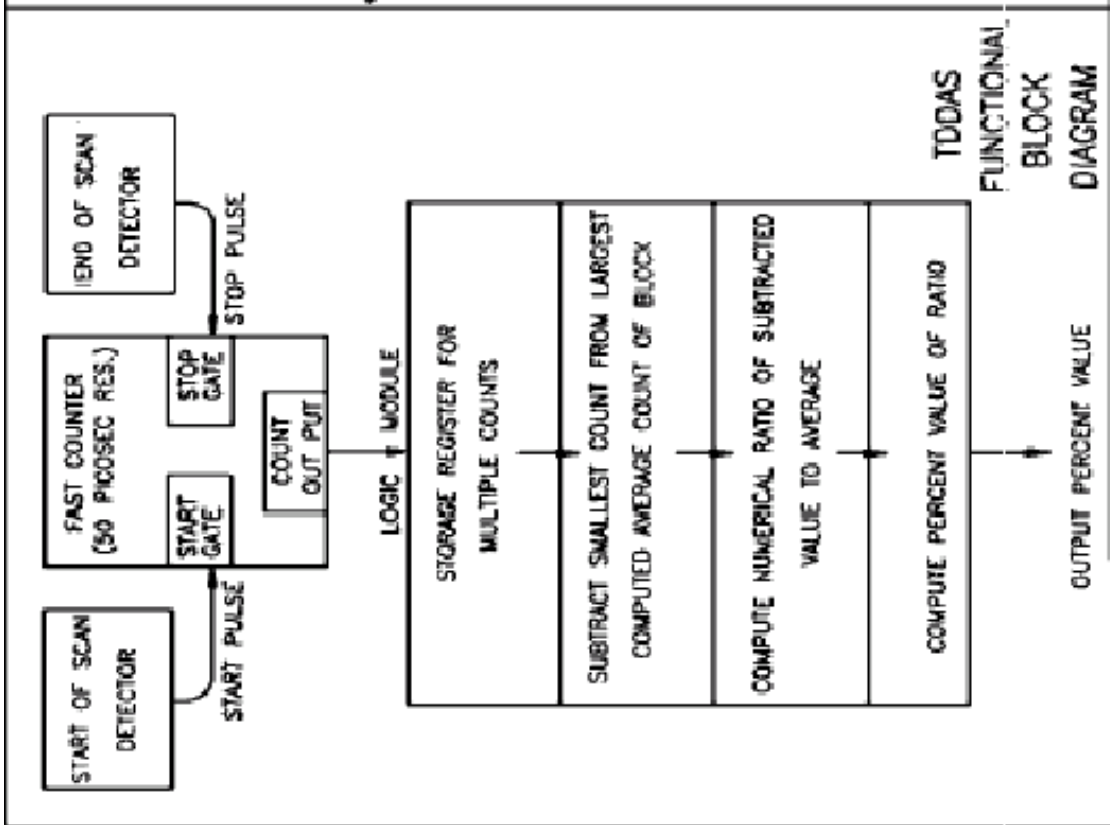

TDDAS FUNCTIONAL BLOCK DIAGRAM

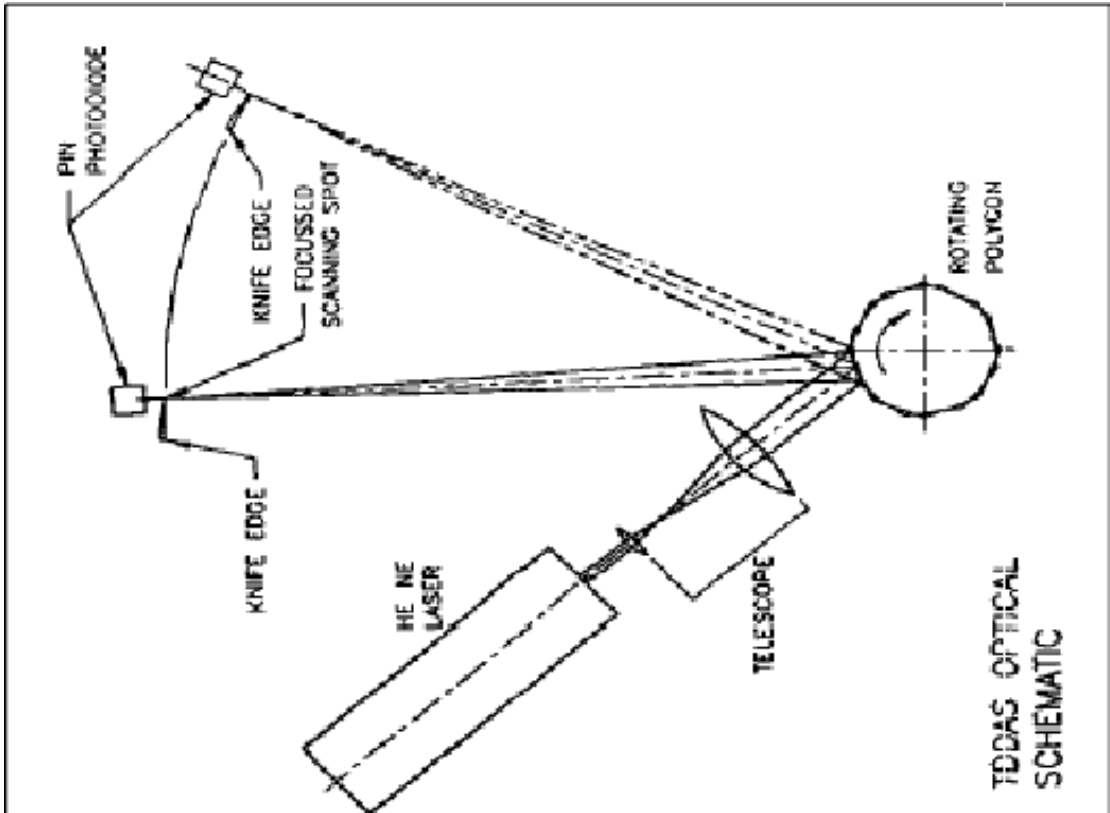

TDDAS OPTICAL SCHEMATIC

DR. D. HANSON 4-72-1

TRAVELER RECORDS

THIS DRAWING HAS BEEN REPRODUCED BY SA-504-106 NATIONAL BUREAU OF STANDARDS

LINCOLN LASER COMPANY
LASER OPTICAL PRODUCTS DIVISION